

Science
& play®

CONSTRUIEȘTE

MECANICA

MAȘINILOR LAMBORGHINI

HURACÁN STO



Reprezentant autorizat pentru piața din
Marea Britanie:
Clementoni UK LTD
Unit 9 – Brook Business Centre –
Cowley Mill Road – UXBRIDGE –
UB8 2FX
ENGLAND – P. +44 203 383 2020
<https://en.clementoni.com/pages/assistance>

Producător:
Clementoni S.p.A.
Zona Industriale Fontenoce s.n.c.
62019 Recanati (MC) - Italy
Tel.: +39 071 75811
www.clementoni.com

V66255

ATENȚIE! Setul este destinat numai copiilor cu vârsta mai mare de 8 ani. Setul include instrucțiuni pentru adulți, care trebuie citite și urmate.

ATENȚIE: pentru a asigura funcționarea adecvată a motorului electric, o cantitate mică de ulei a fost adăugată în timpul producției. În cazul unor temperaturi ridicate, este posibil ca această substanță să se topească și să devină uleioasă. Dacă motorul din set este murdar, curățați-l folosind șervețele de hârtie. Uleiul folosit nu este toxic sau periculos.

Citiți și păstrați instrucțiunile pentru referințe ulterioare.



SUNMAN SAN. MAM. ITH. IHR. VE TIC. A.S.
Centrul Logistic Sunman, Strada Turgut Özal nr. 125
Cayirova 41420 KOCAELI, TURCIA
Tel.: +90 216 499 80 80; Fax: +90 216 314 67 20
www.sunman.com.tr; info@sunman.com.tr

Importator:
S.C. INTERTOY ZONE S.R.L.
București, Sector 2, Strada Căminului nr. 6
Tel.: 021 405 06 09

 **Clementoni®**

INSTRUCȚIUNI PENTRU ADULTUL CARE SUPRAVEGHEAZĂ

ACTIVITATEA: Jucăria este recomandată copiilor cu vârsta mai mare de 8 ani. Un adult trebuie să fie de față pentru a supraveghea procesul de asamblare, precum și manipularea și instalarea componentelor electrice.

ÎNDEPĂRTAREA ȘI INSTALAREA BATERIILOR

Bateriile trebuie instalate și înlocuite numai de către adulți. Asigurați-vă că dispozitivul este oprit.

- 1 Folosiți o șurubelniță pentru a desface șurubul din capacul compartimentului pentru baterii.
- 2 Îndepărtați bateriile consumate.
- 3 Introduceți 4 baterii AA de 1,5V noi (nu sunt incluse) în compartiment, respectând indicațiile de polaritate din compartiment și de pe baterii.
- 4 Reînșurubați capacul compartimentului pentru baterii.
- 5 Porniți dispozitivul și asigurați-vă că bateriile sunt instalate corect.

Cereți întotdeauna ajutorul unui adult pentru a instala bateriile!



Alimentare: 6V d.c.

Baterii: 4 x 1,5V AA

Bateriile nu sunt incluse.

ALTE RECOMANDĂRI:

- Bateriile pot fi periculoase dacă sunt înghițite; țineți-le departe de accesul copiilor.
- Îndepărtați bateriile dacă produsul nu va fi folosit pentru mult timp.
- Nu încercați să desfaceți bateriile.
- Nu aruncați bateriile în foc.

FOLOSIREA ÎN SIGURANȚĂ A BATERIILOR/ACUMULATORILOR

ATENȚIE!

- Instalați întotdeauna bateriile în pozițiile indicate de simbolurile de polaritate + și -.
- Îndepărtați bateriile consumate din produs.
- Nu scurtcircuitați bornele de alimentare.
- Nu atingeți contactele din compartiment pentru baterii, deoarece acest lucru poate provoca un scurtcircuit.
- Scoateți acumulatorii din produs înainte de a-i încărca. A se încărca numai sub supravegherea unui adult.
- Nu încercați să încărcați baterii nereîncărcabile.
- Nu folosiți în același timp baterii vechi și noi sau baterii de tipuri diferite (standard, alcaline sau reîncărcabile).
- Protejați mediul înconjurător! Duceți produsele electrice și electronice și bateriile de care nu mai aveți nevoie la un centru de colectare corespunzător. Nu le aruncați împreună cu deșeurile menajere.

LAMBORGHINI HURACÁN STO

„Modelul Huracán STO este întruchiparea cea mai pură a tradiției Lamborghini Squadra Corse [...] Soluțiile tehnice vaste și experiența acumulată în programele noastre Super Trofeo și GT3 au fost rafinate la Huracán STO pentru a-i permite șoferului să trăiască emoția unui șofer de curse, la volanul unui Lamborghini, o mașină atestată pentru folosirea pe șosele și capabilă să bată orice record pe pistă.”

Maurizio Reggiani, Chief Technical Officer



DIMENSIUNI

Lungime 4,5 m

Lățime 2,2 m

Înălțime 1,2 m

Greutate (fără combustibil) 1,339 kg

MOTOR

Motor V cu 10 cilindri în unghi de 90°, cu IDS+MPI dual injection

Capacitate cilindrică 5.204 cm³

Putere maximă 470 kW/640 cai putere la 8.000 rpm

PERFORMANȚE

Viteză maximă 310 km/h

Accelerare de la 0 la 100 km/h: 3 s



Orificiile de ventilare de pe capota din față permit accesul unui flux mai mare de aer, pentru a susține răcirea motorului.



Peste 75% din caroseria de pe Huracán STO este realizată din fibră de carbon, care permite crearea unei structuri complexe ca și cum ar fi o singură componentă, pentru integritate structurală suplimentară și reducerea greutății mașinii.



În timpul manevrelor la viteză mare, „aripioara de rechin” montată pe capotă și spoilerul ajustabil de pe spate îmbunătățesc stabilitatea mașinii atât pe secțiuni drepte de drum, cât și în curbe.



LAMBORGHINI HURACÁN STO



Urmați instrucțiunile interactive 3D din aplicație.



ÎNAINTE SĂ ÎNCEPEȚI!

Diblul portocaliu are patru dinți care pot fi folosiți pentru a uni barele perpendicular.

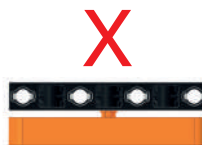
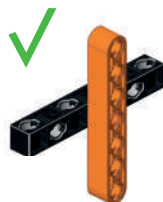
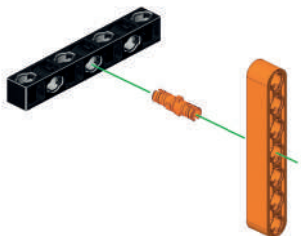

Diblul albastru are doi dinți care pot fi folosiți pentru a uni barele în paralel.

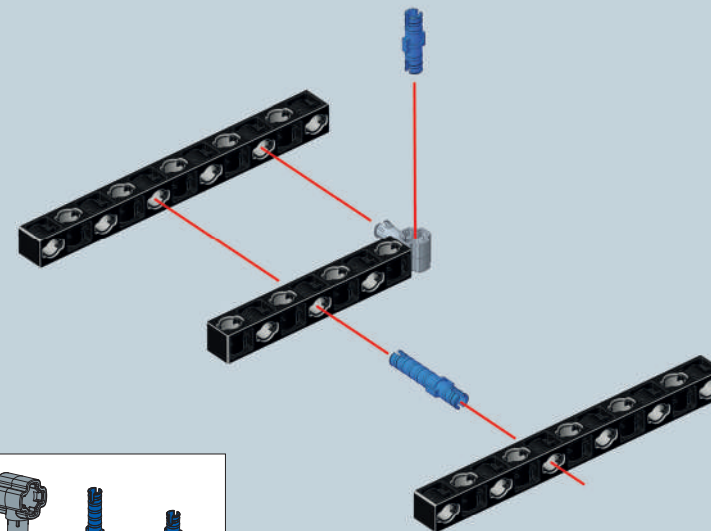
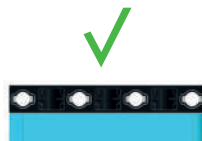
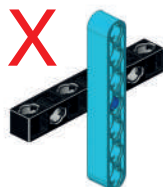
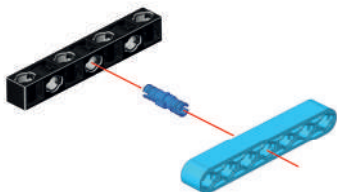

1

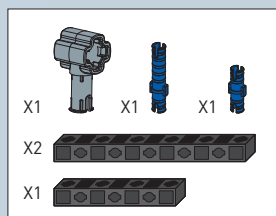

2

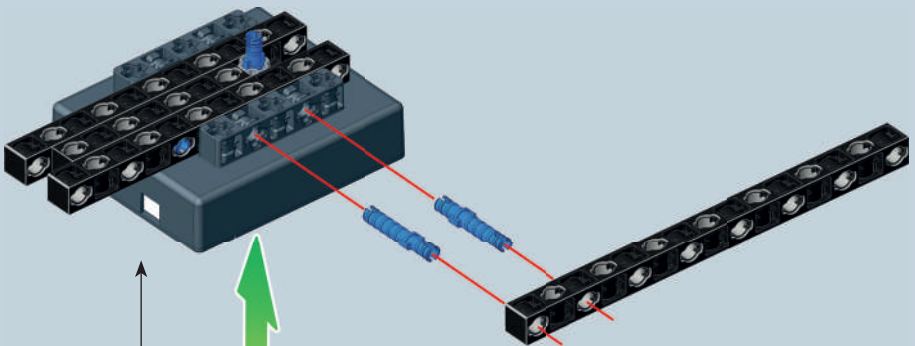

Verificați cu atenție direcția compartimentului pentru baterii.

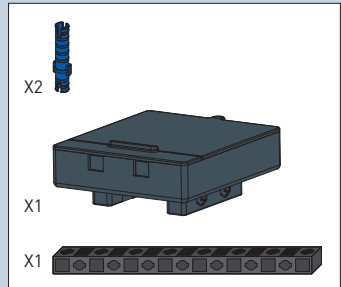
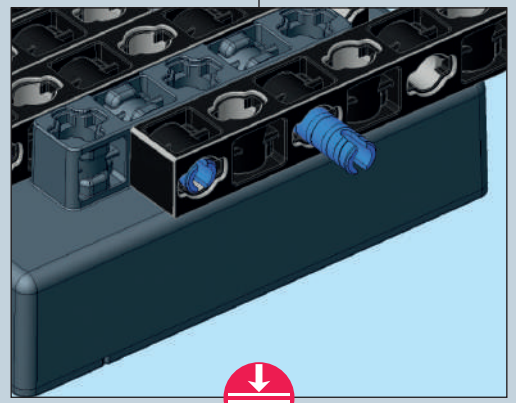

3

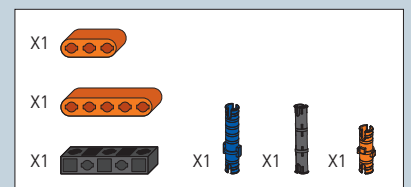
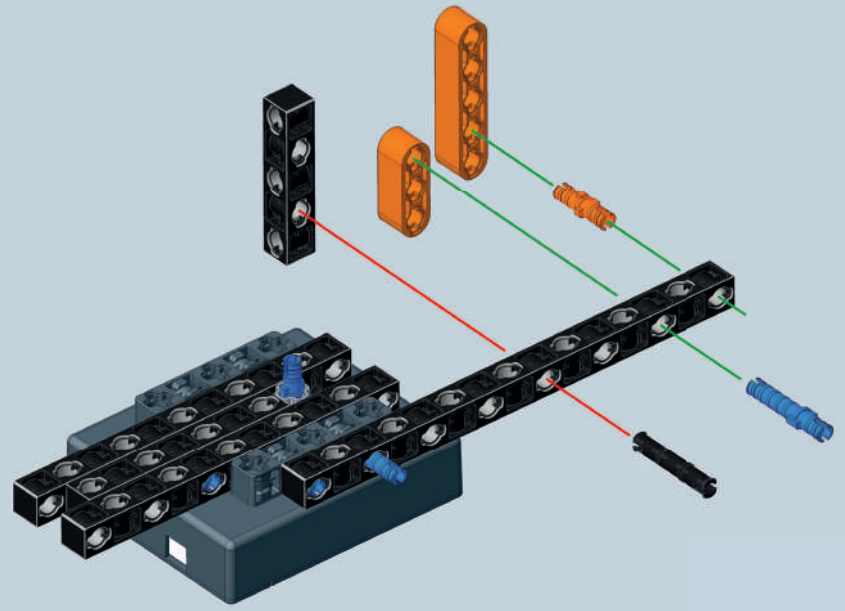

4

- X1
- X1
- X1 X3 X1 X1
- X1

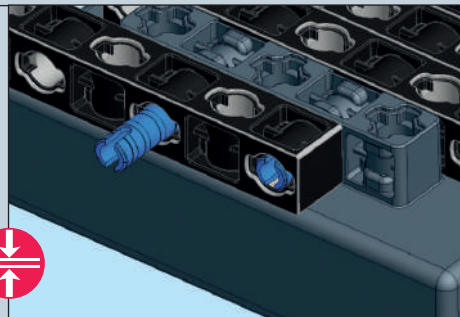
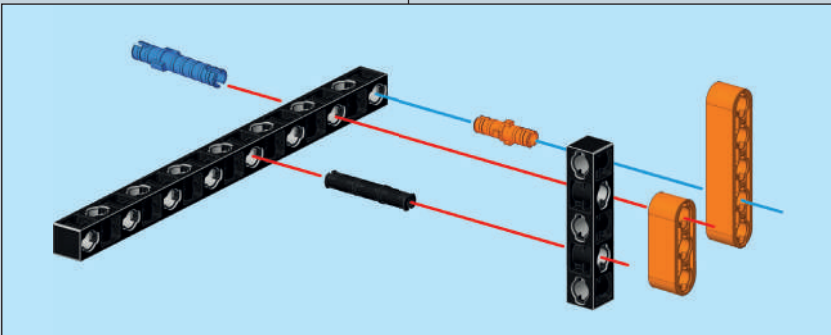
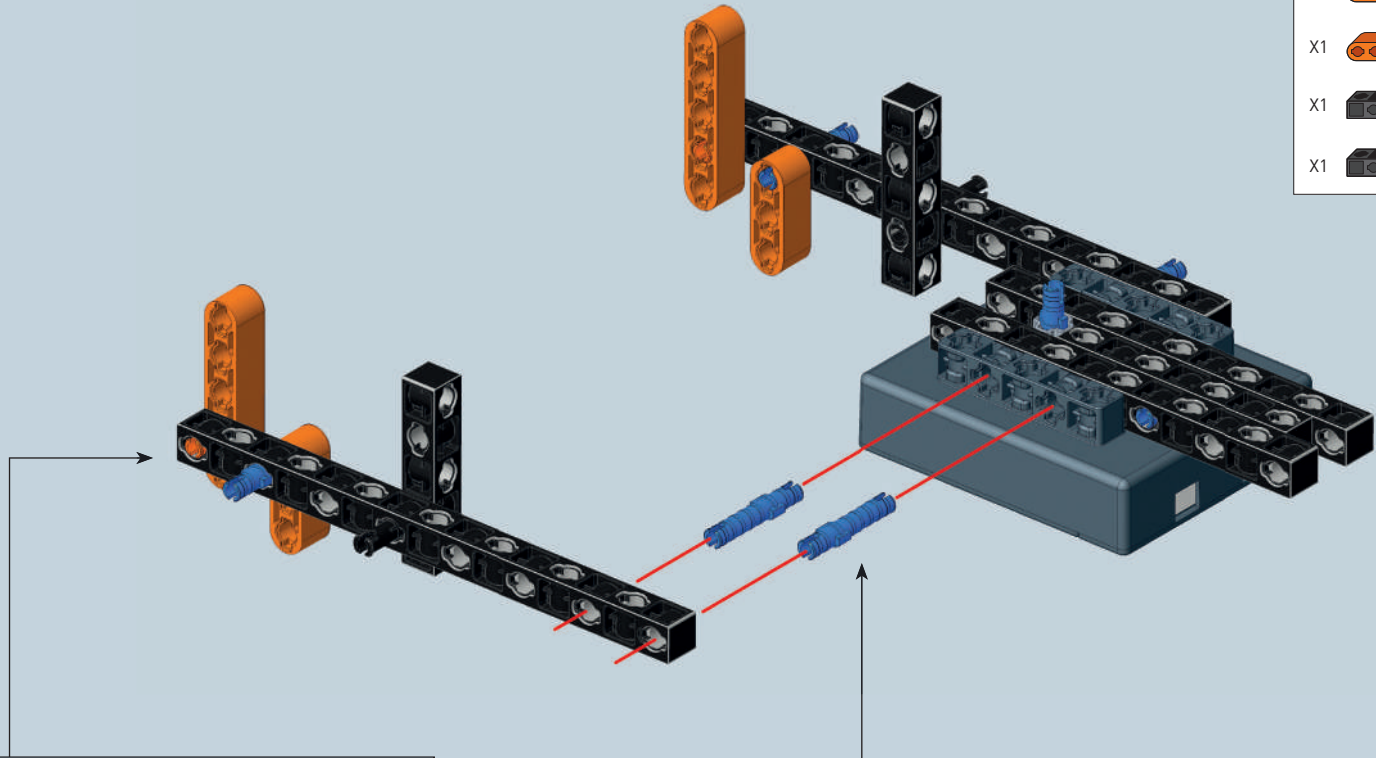

5

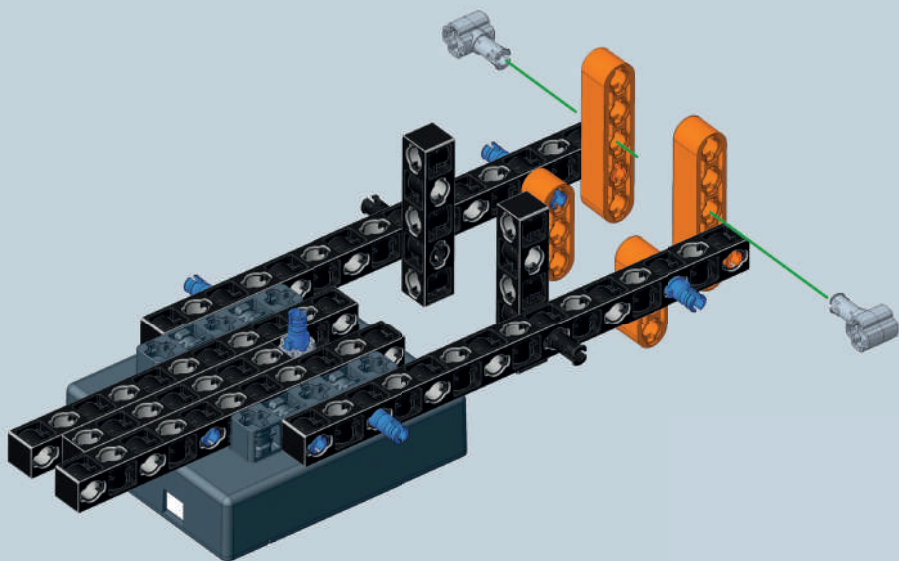

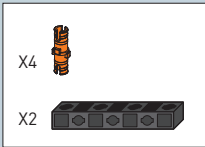
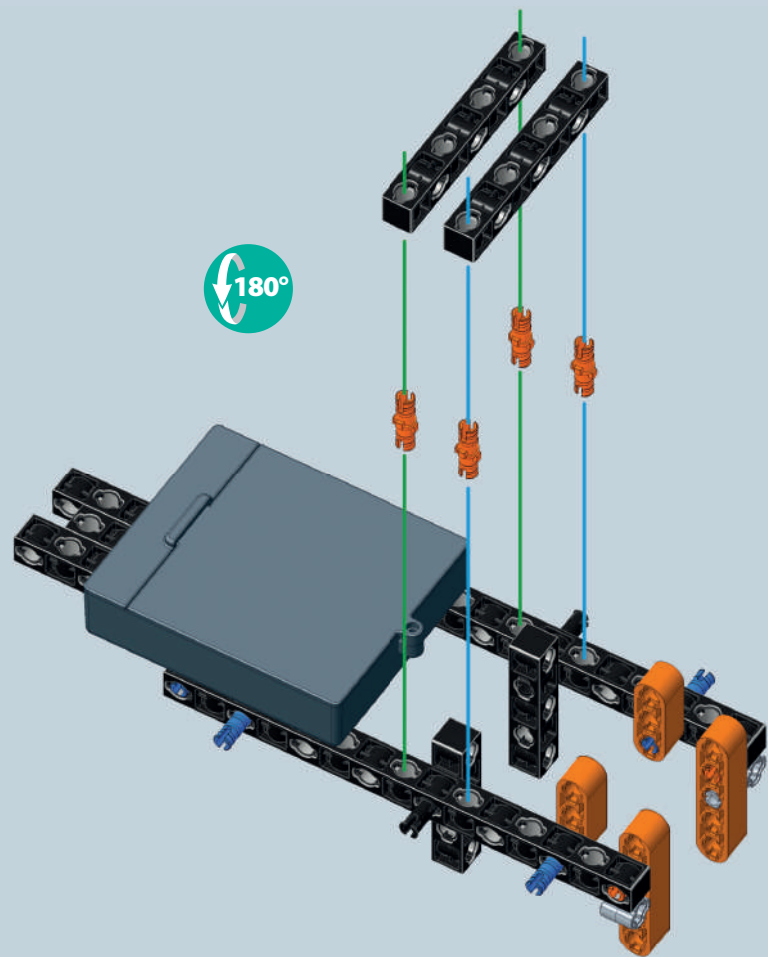

6

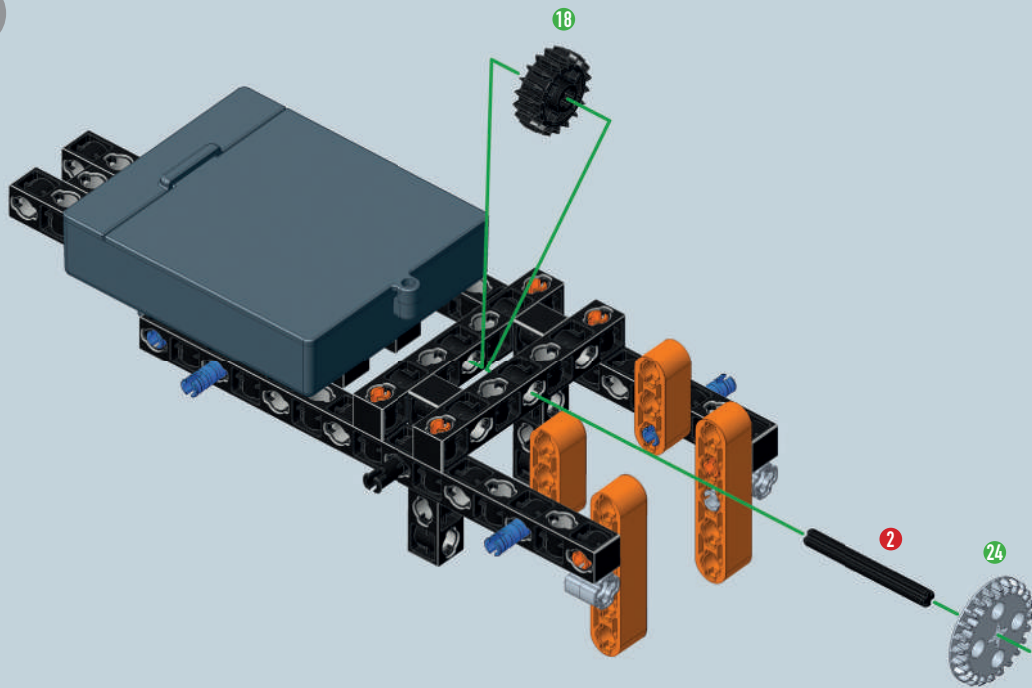

7



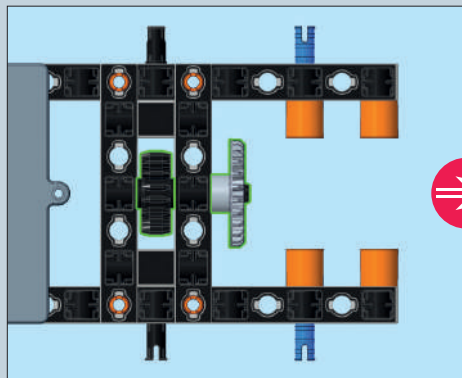

- X1  18
- X1  24
- X1  2

1:1  2

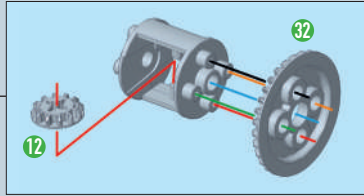
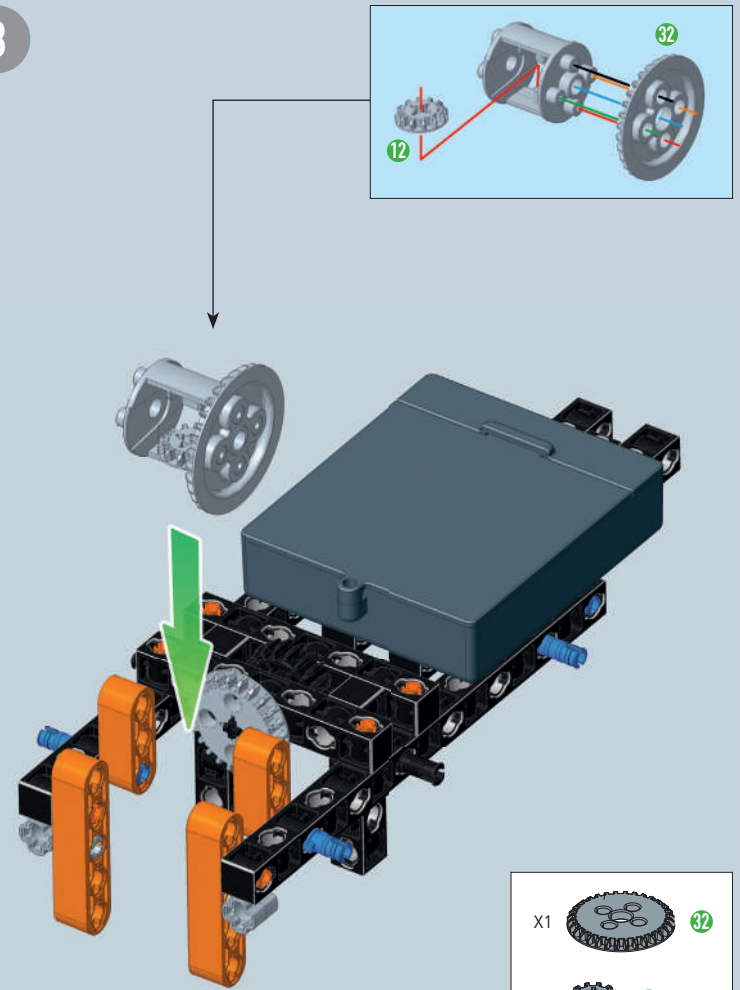

8



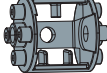

- X1  32
- X1  12
- X1 

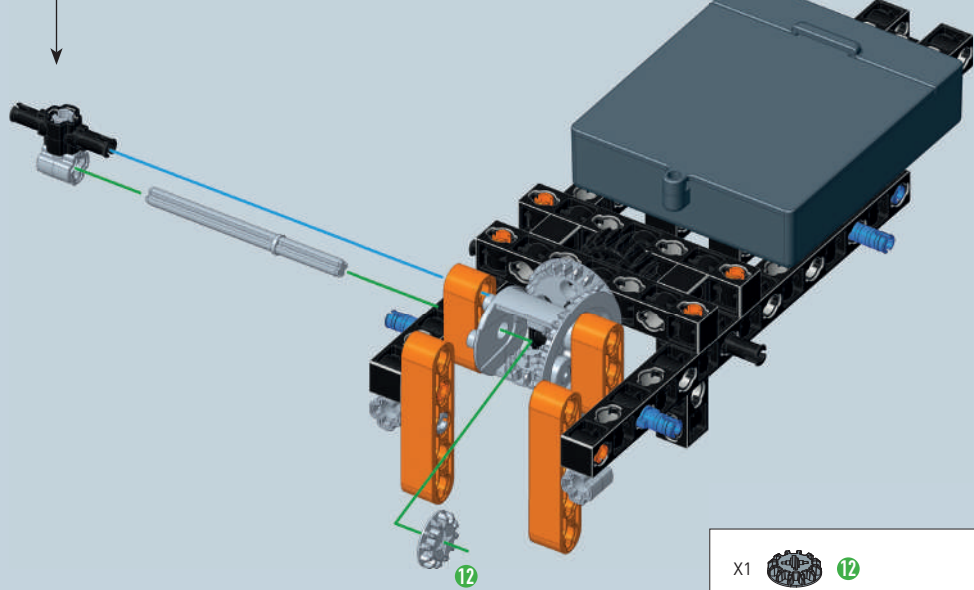
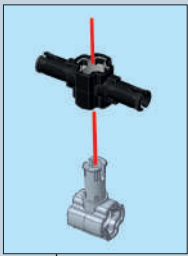
9

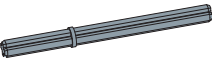

12

- X1  12
- X1 
- X1 
- X1 

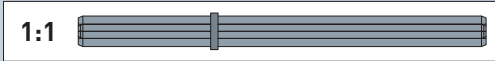

10

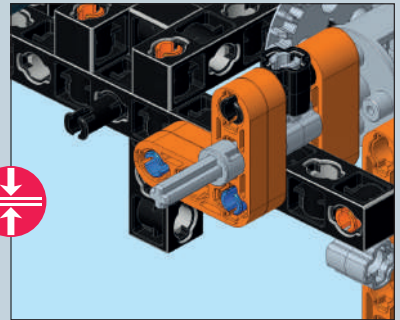
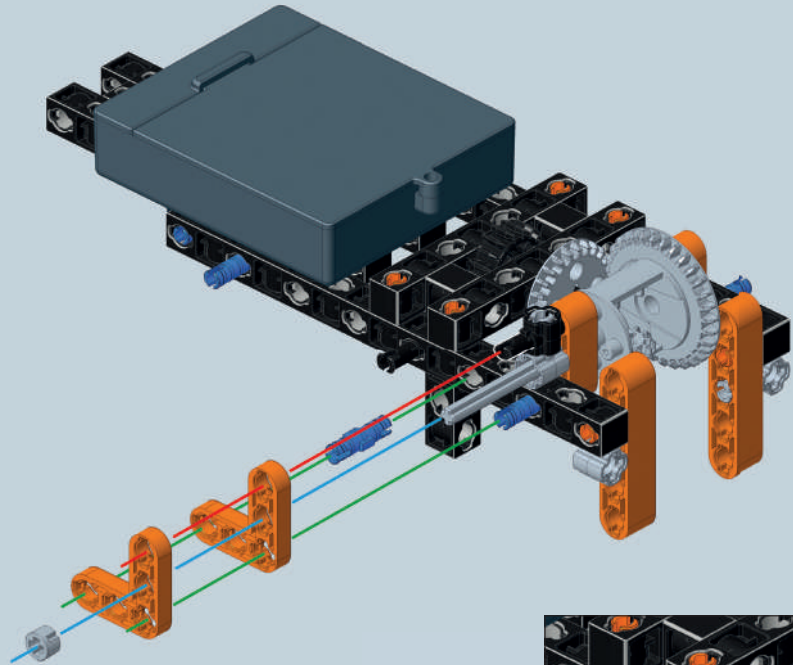

- X2 
- X1 
- X1 

11

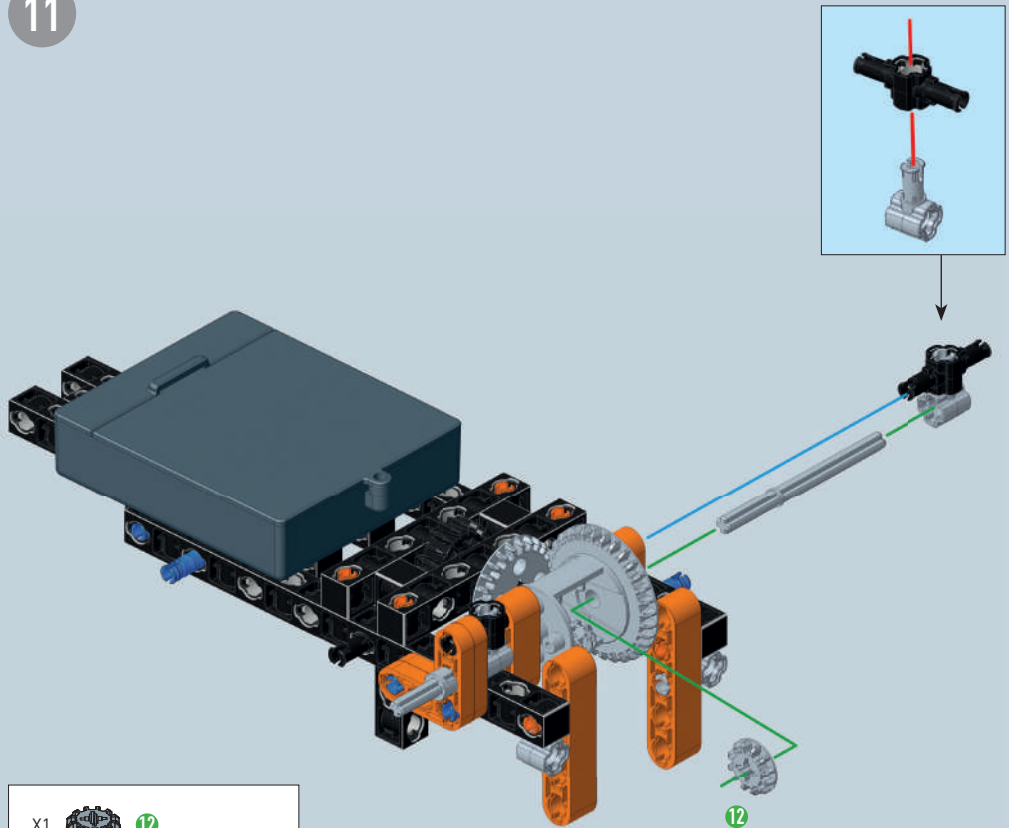

- X1 12
- X1
- X1
- X1





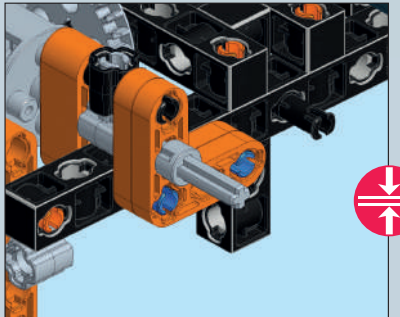
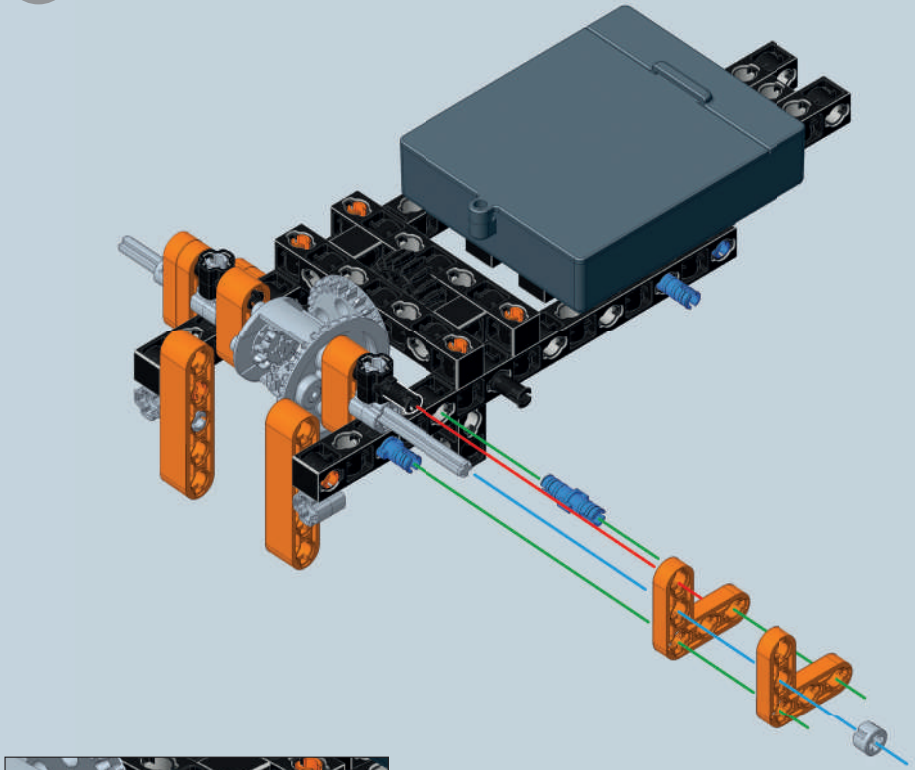

12

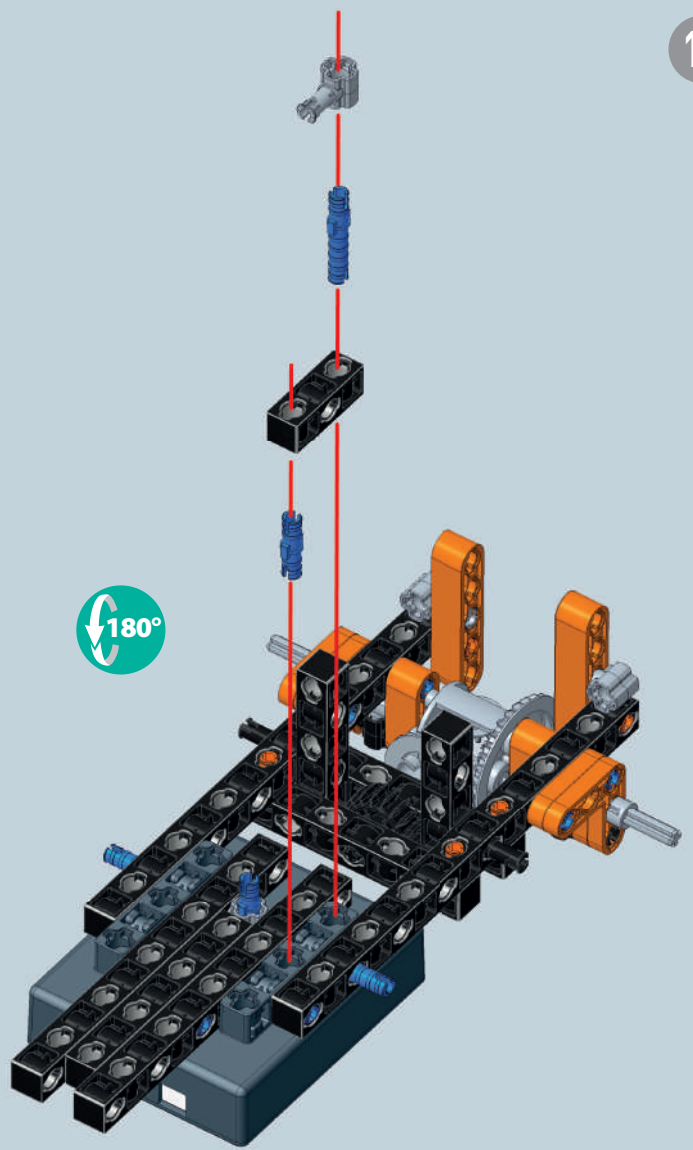

- X2
- X1
- X1



13

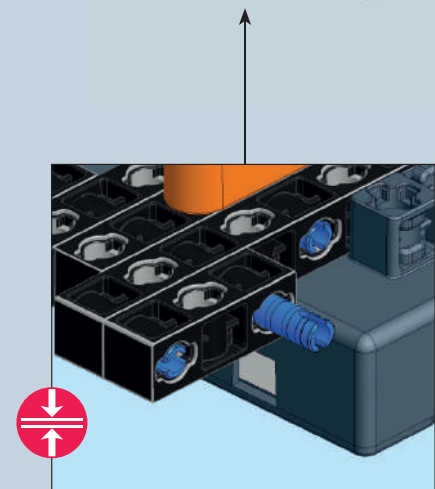
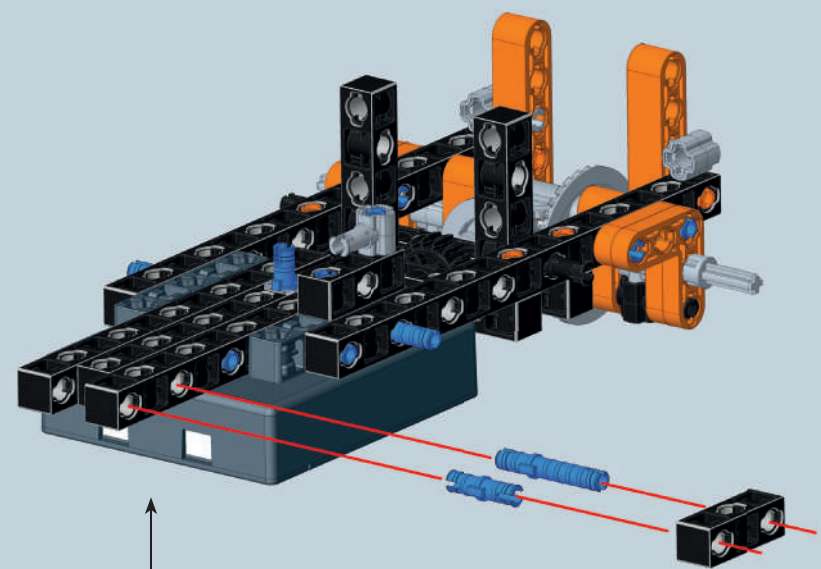

- X1 
- X1 
- X1 

14



- X1 
- X1 
- X1 

15

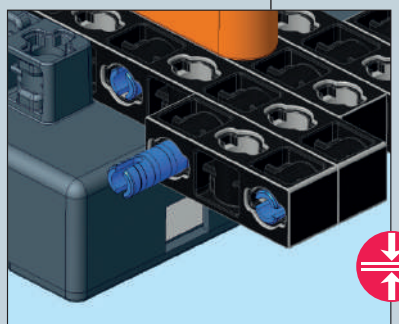
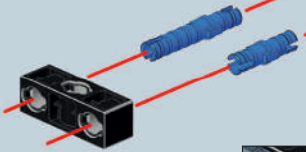
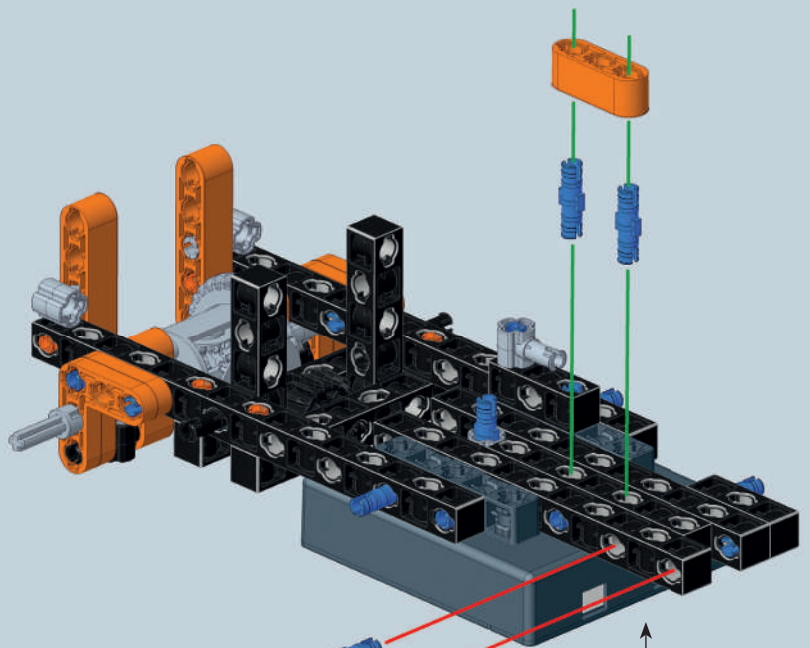

- X1
- X3
- X1
- X1

16

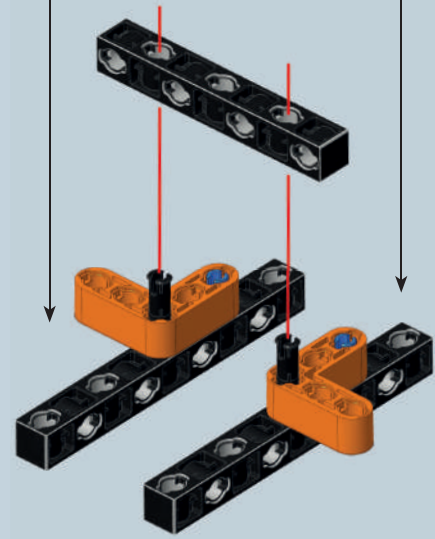
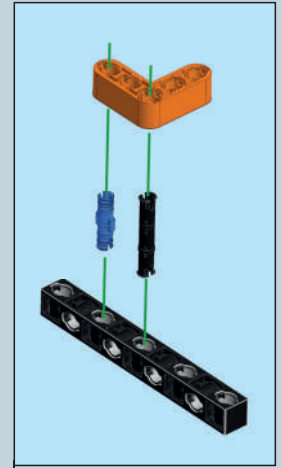
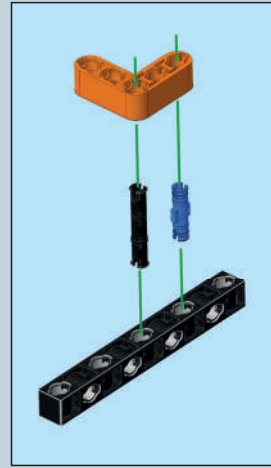

- X2
- X2
- X2
- X1
- X2



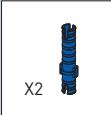
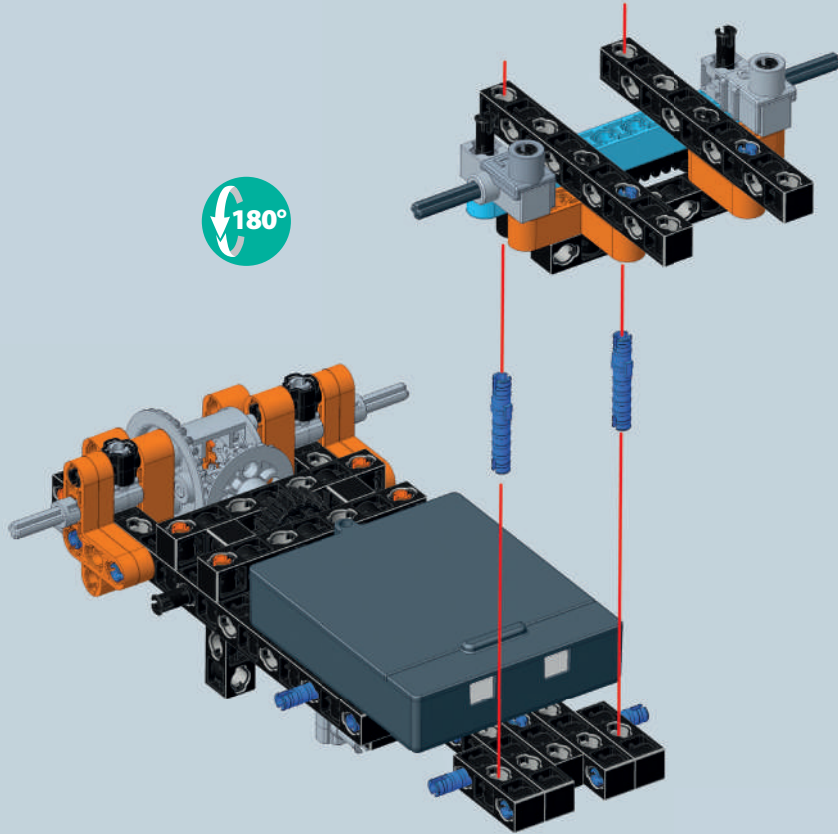

18

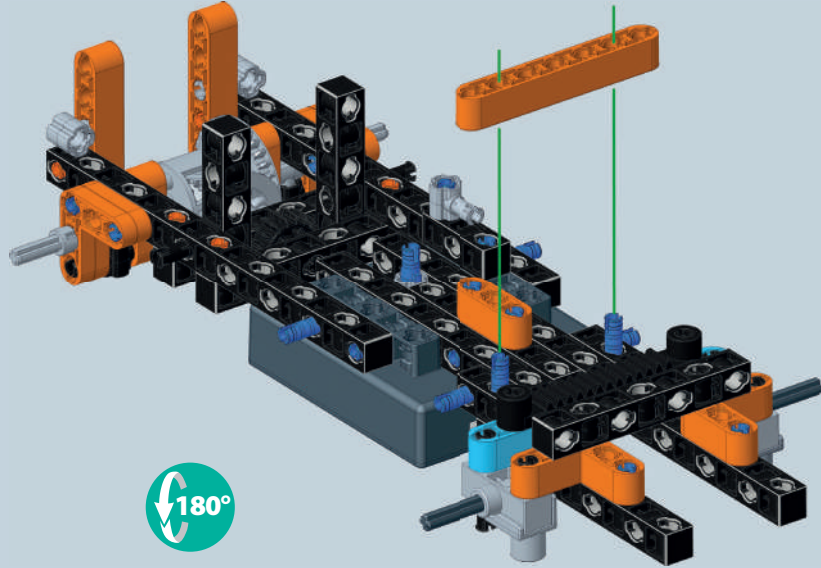

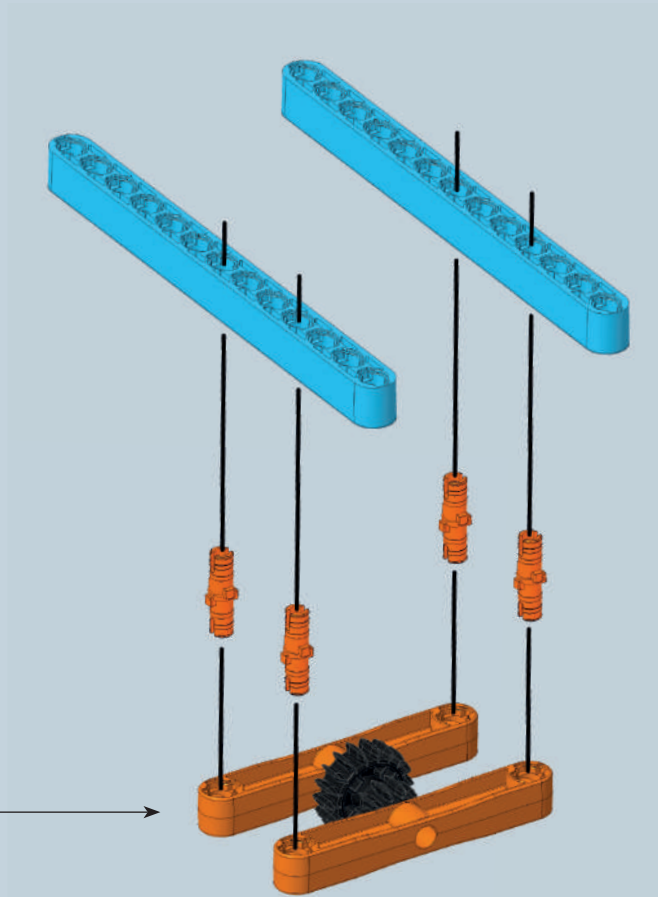
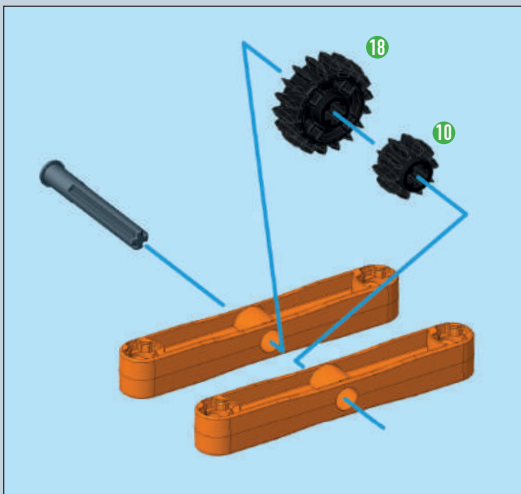
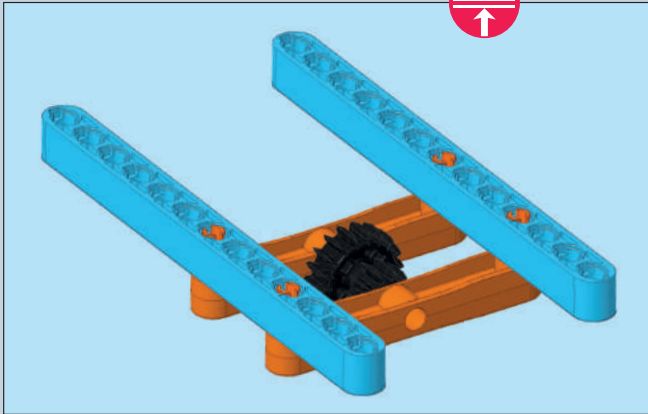
19



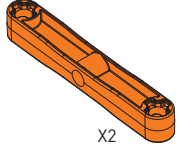

- X1  X1  X4 
- X1 
- X2 
- X2 

21

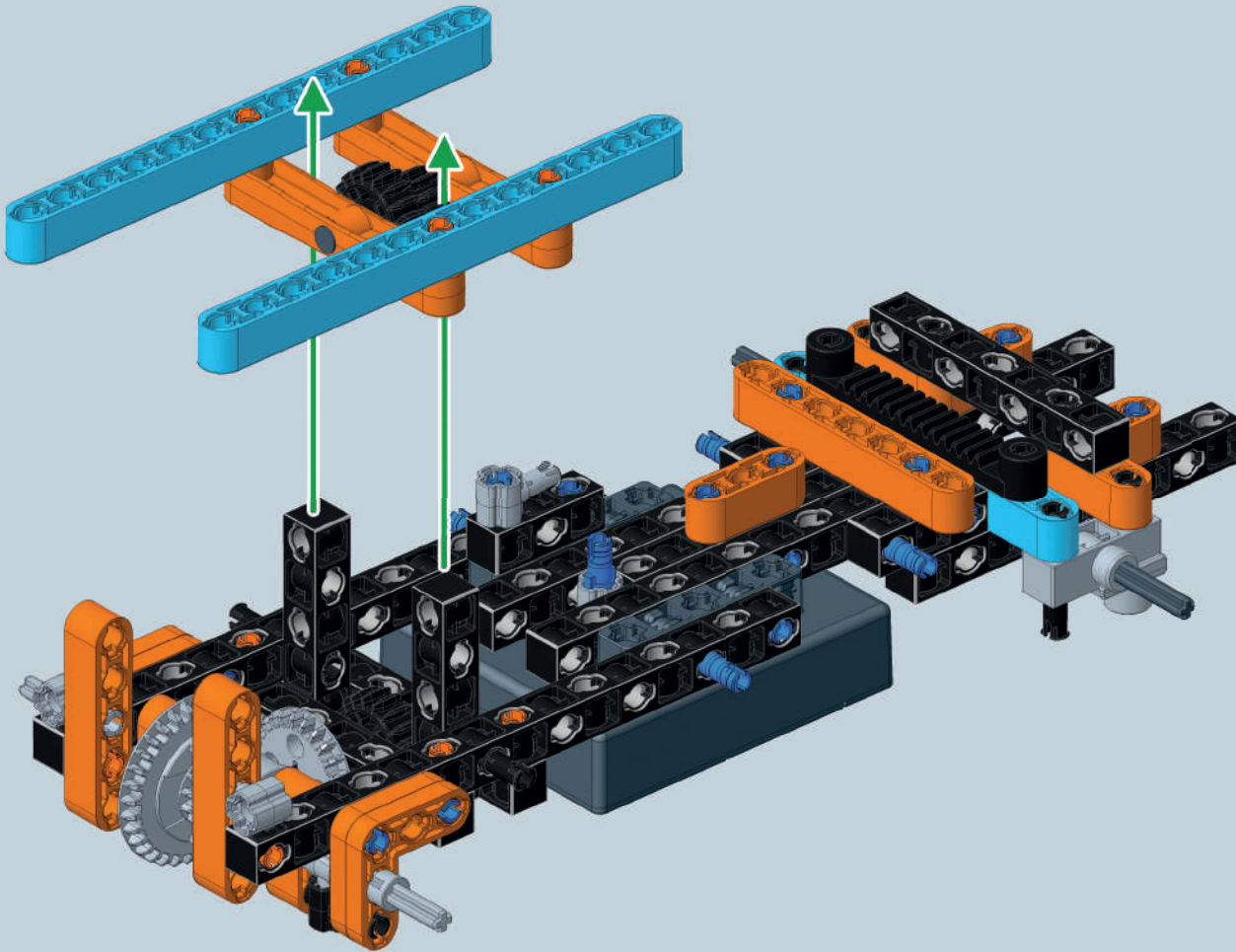

VERIFICAȚI ASAMBLAREA!

Întreaga structură care tocmai a fost poziționată se mută înainte și înapoi cu o poziție.

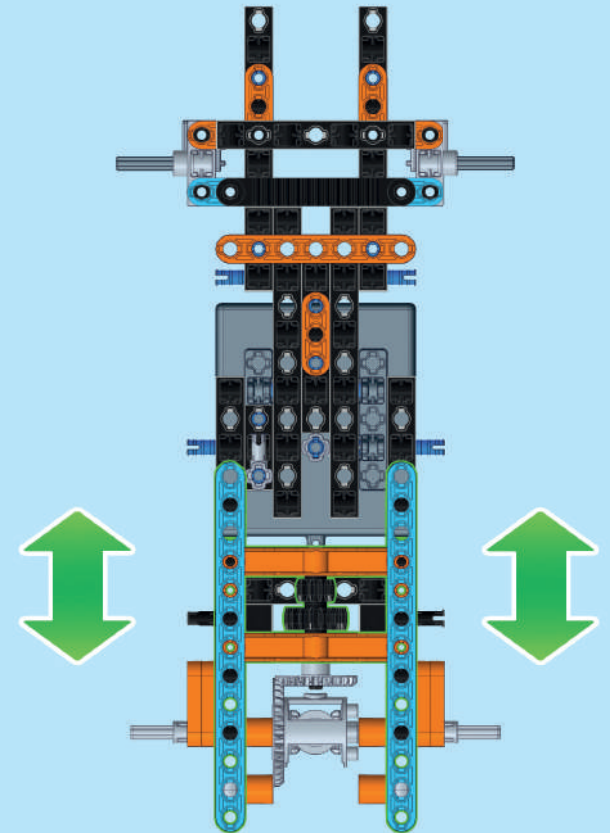

22

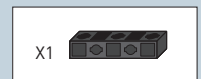
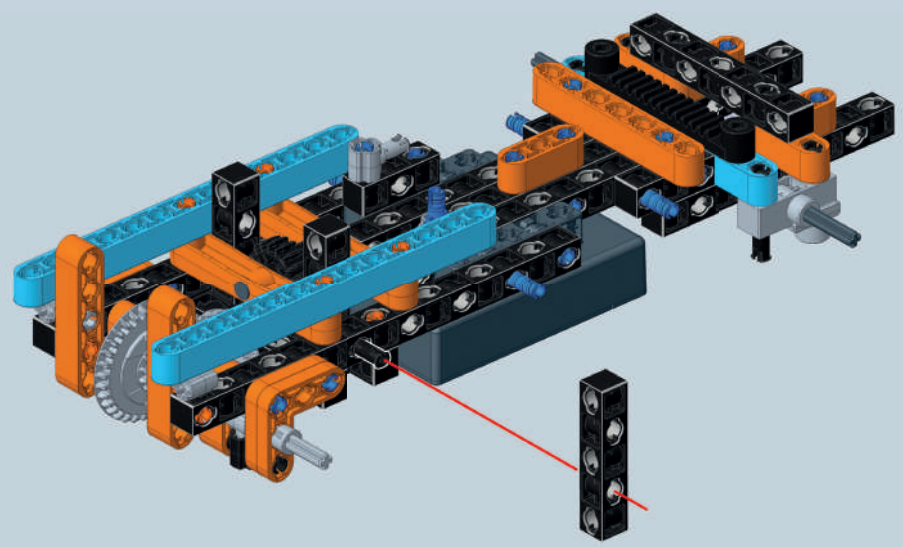

23

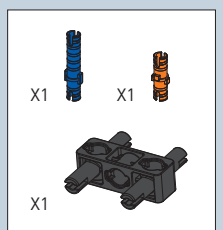
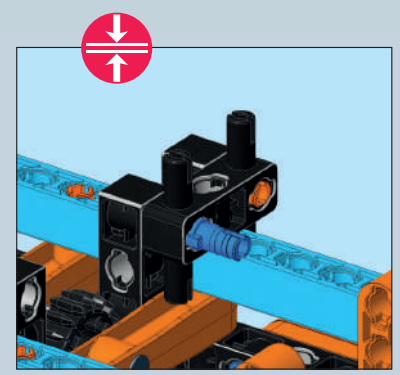
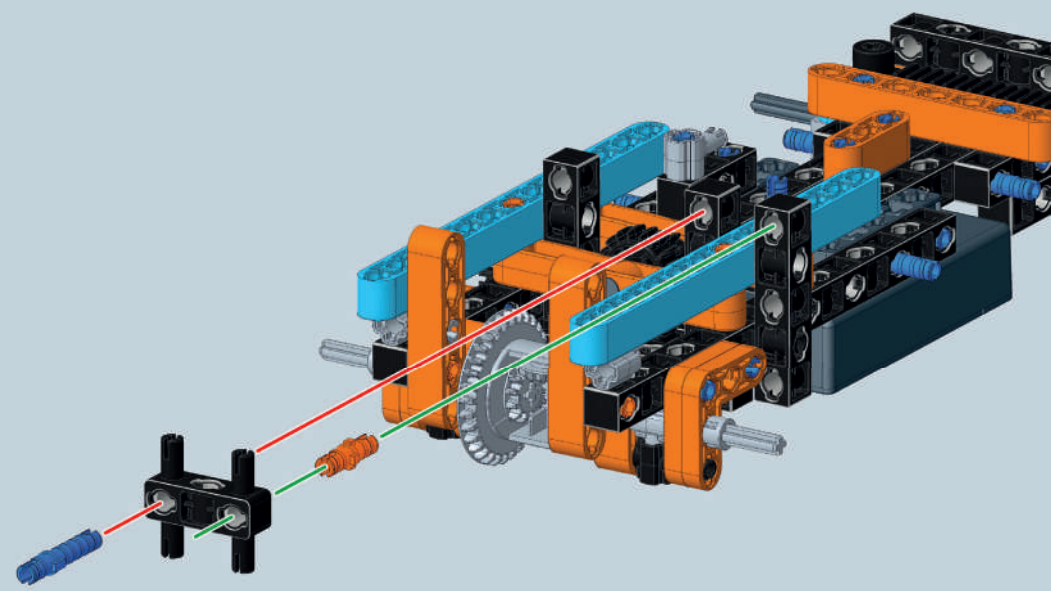

24

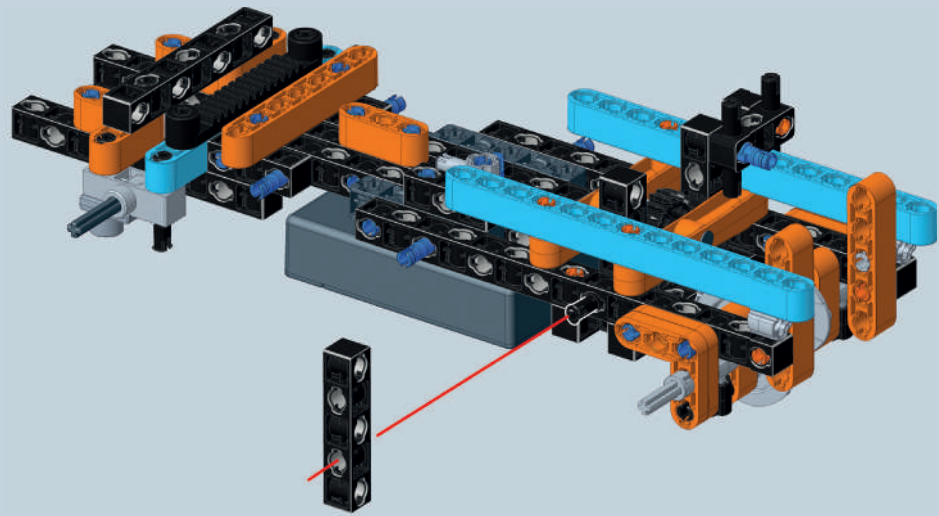

25

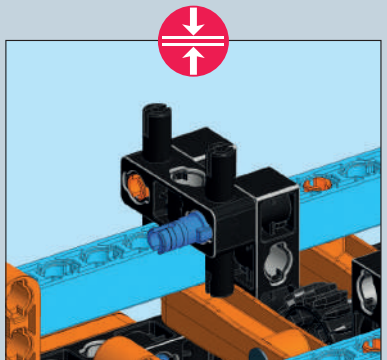
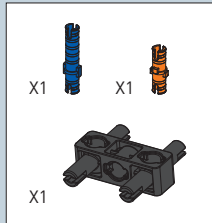
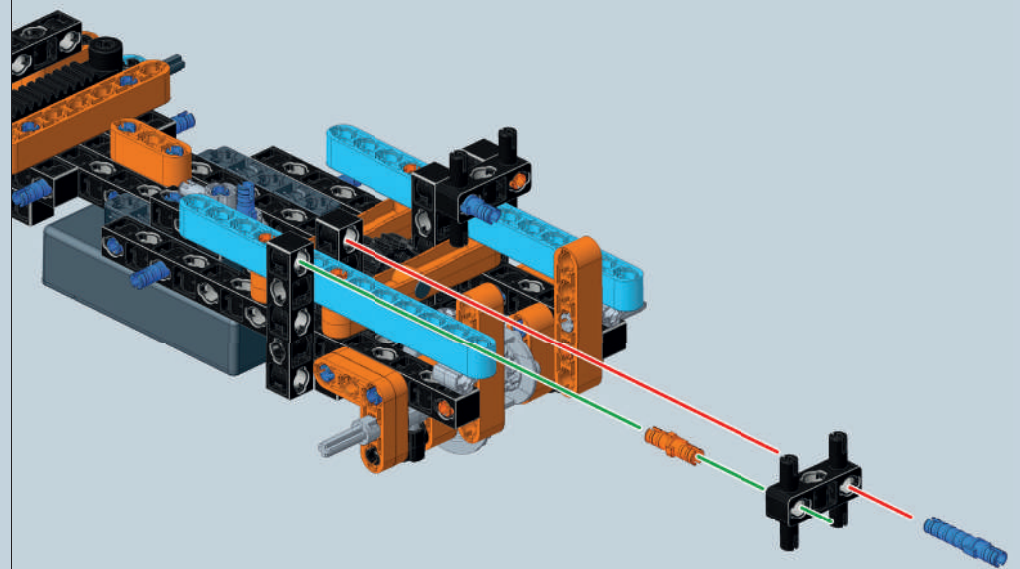

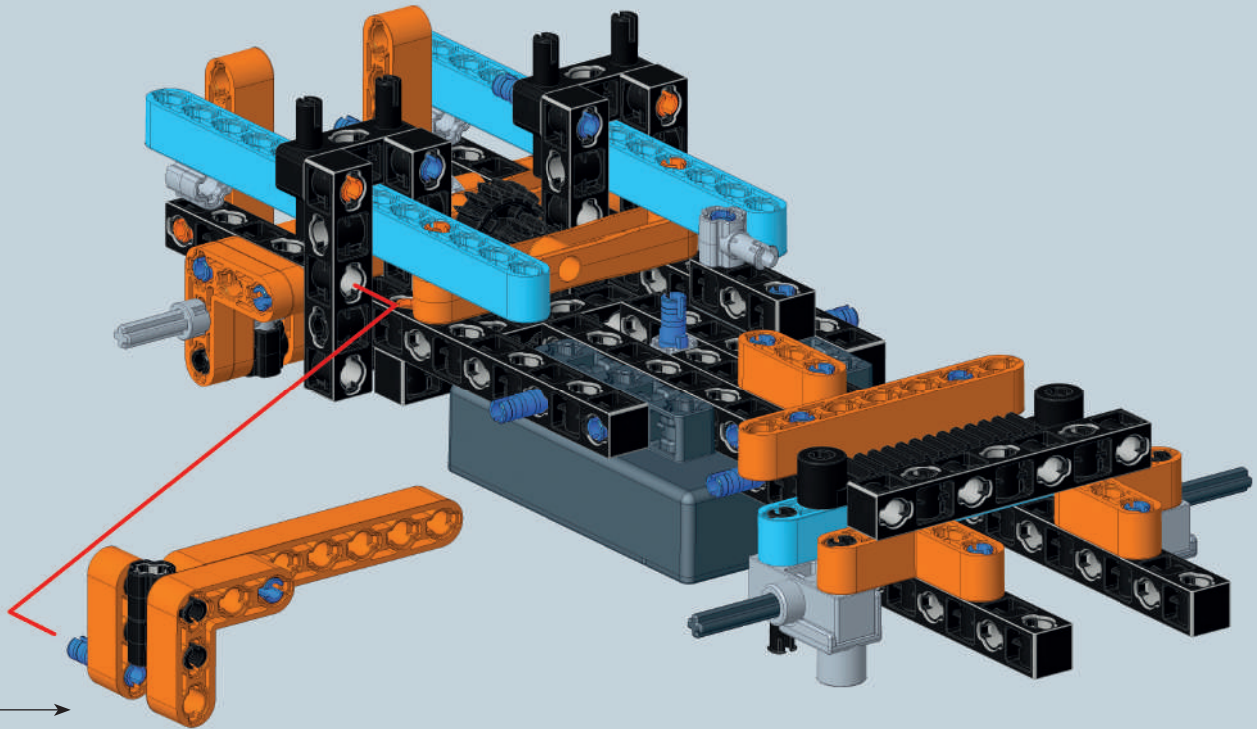
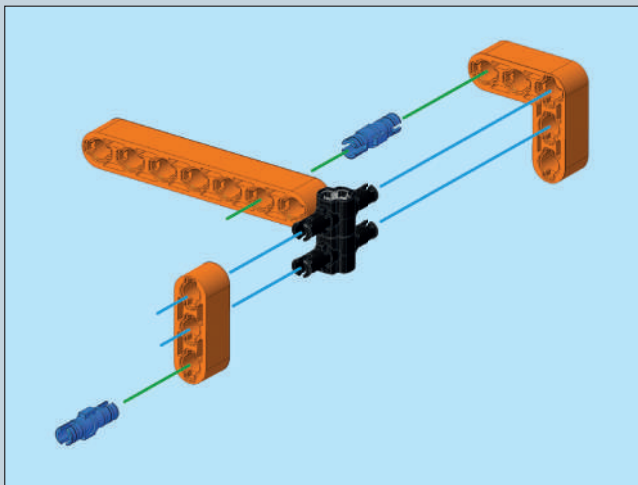
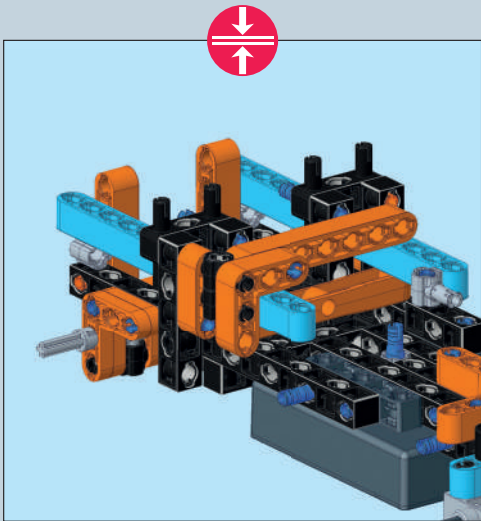

- X1
- X1 X2
- X1
- X2

27

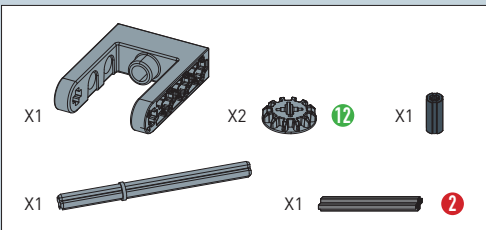
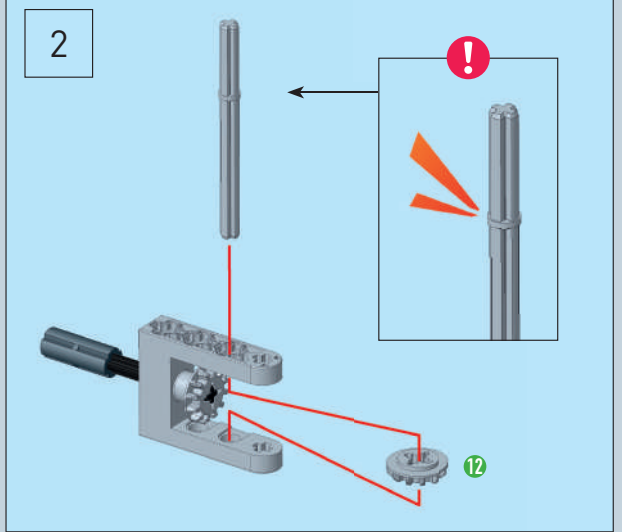
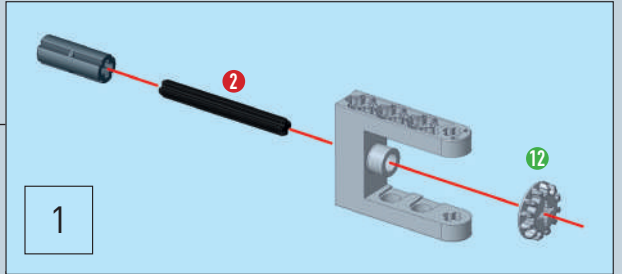
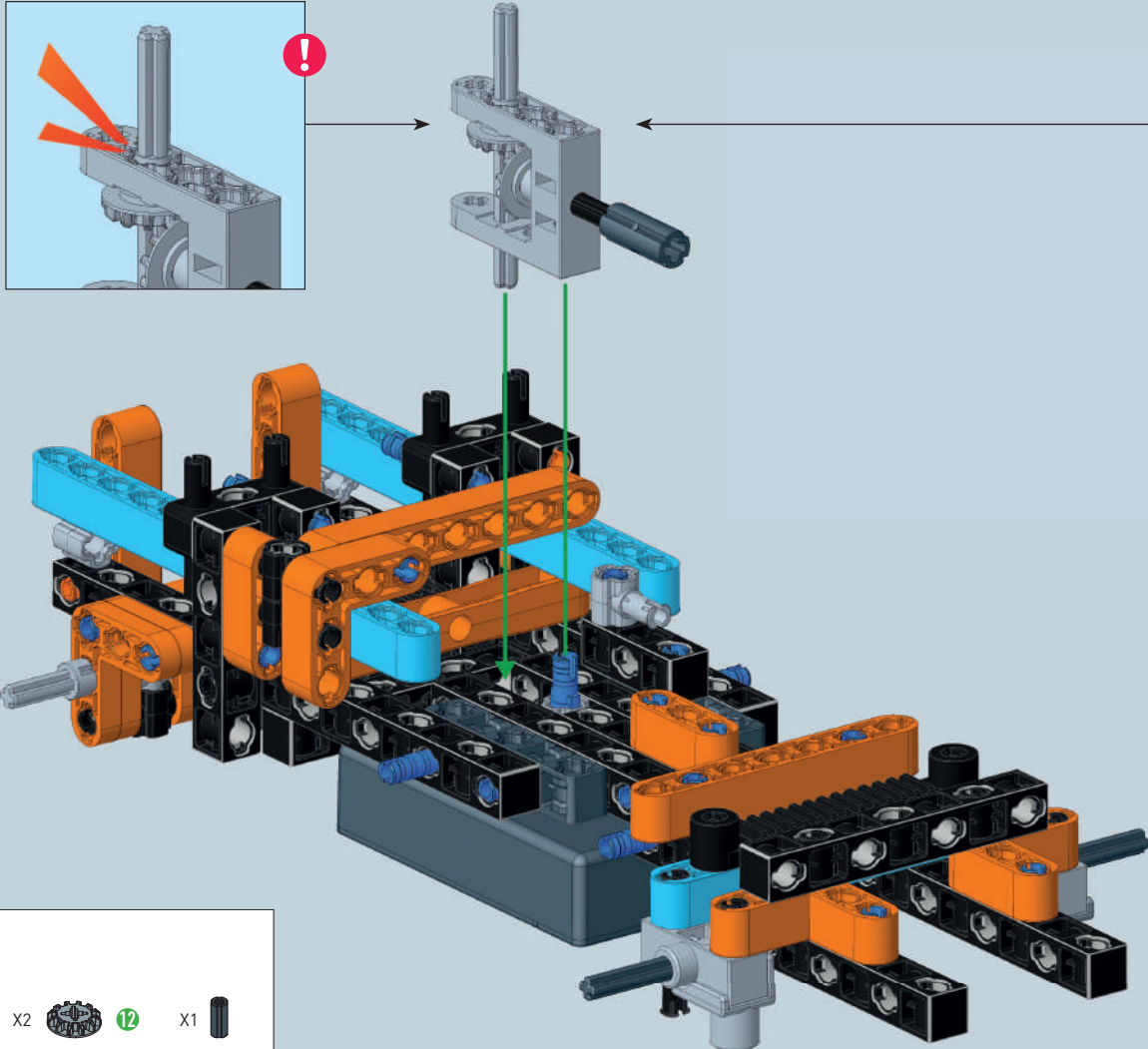



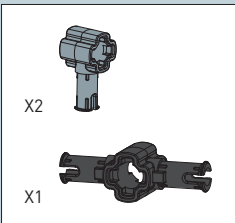
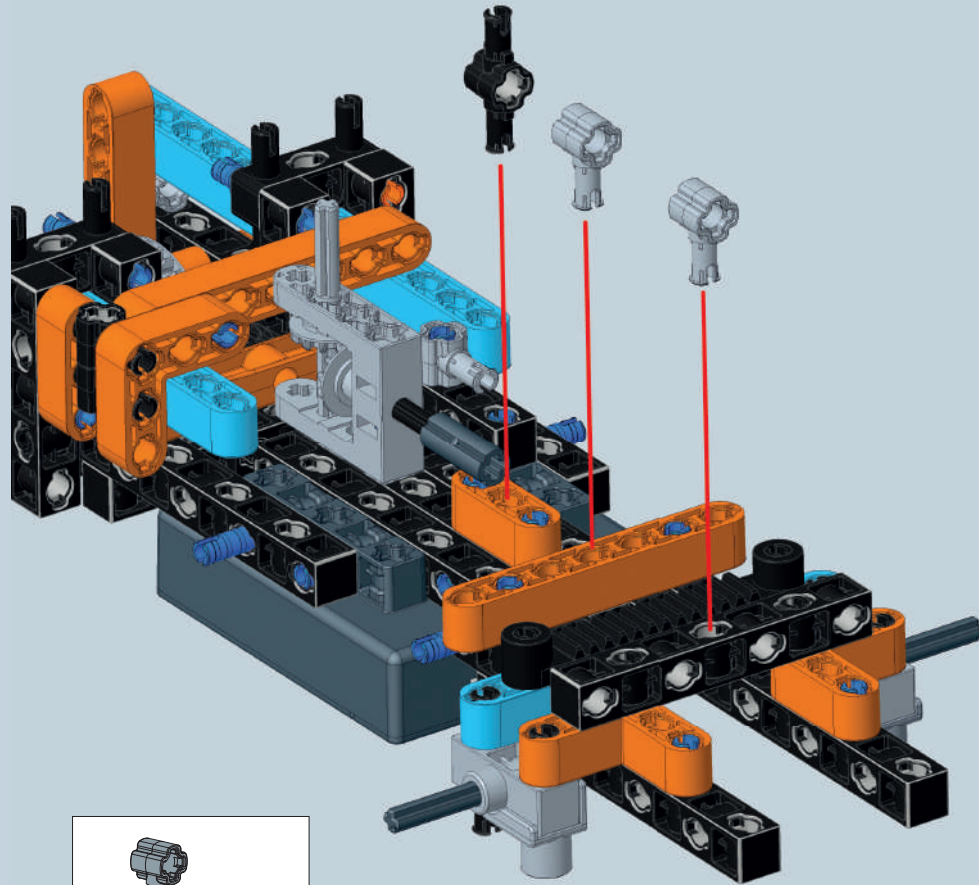

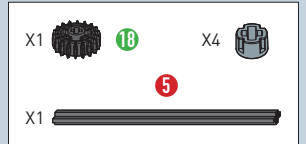
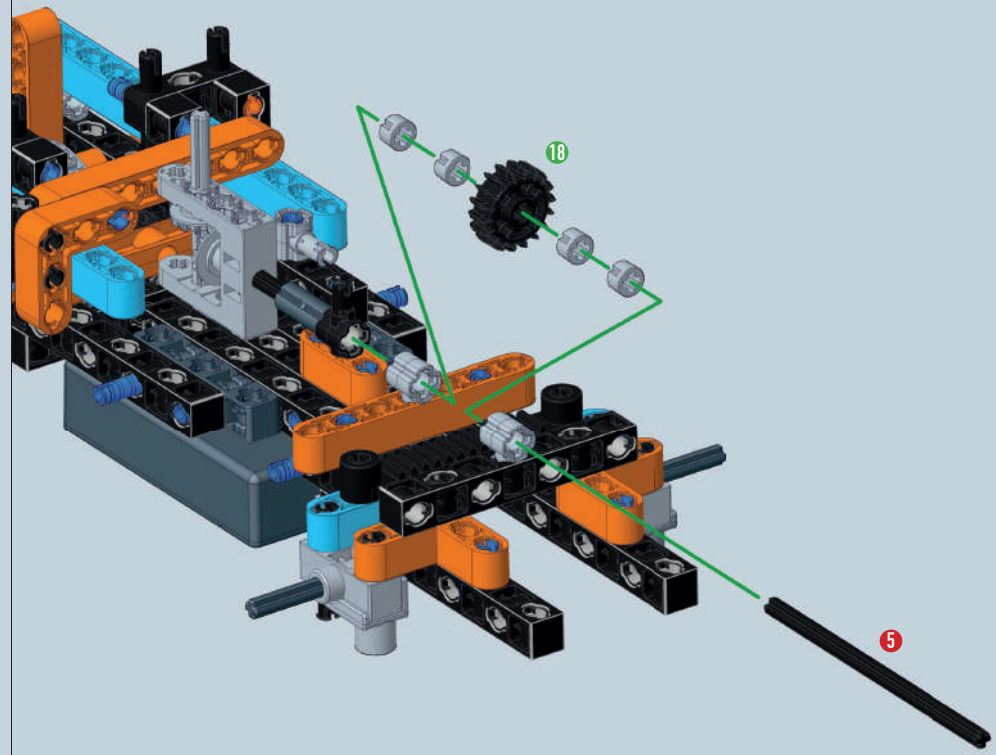

28

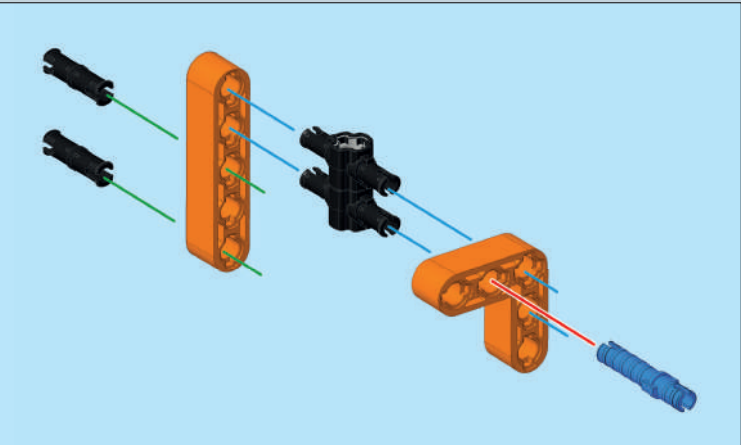
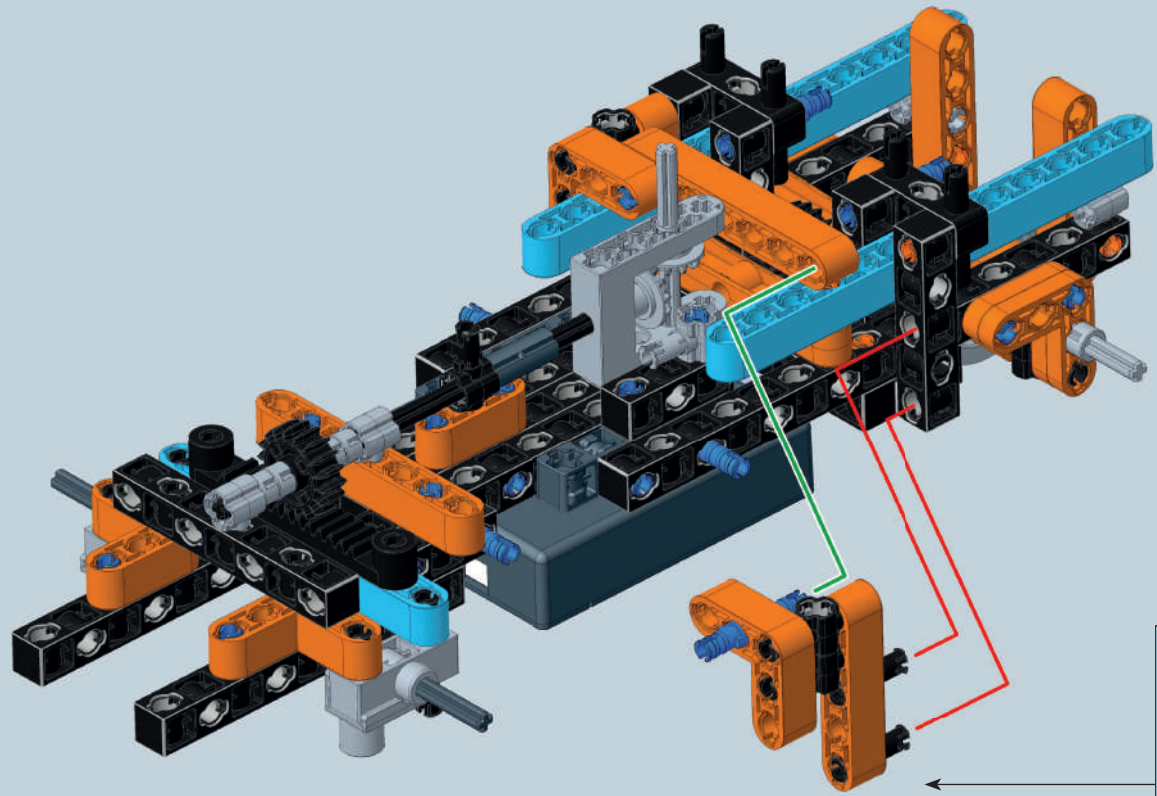

29





- X2 
- X1 
- X1 
- X1 
- X2 

31

32

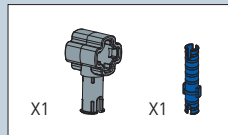
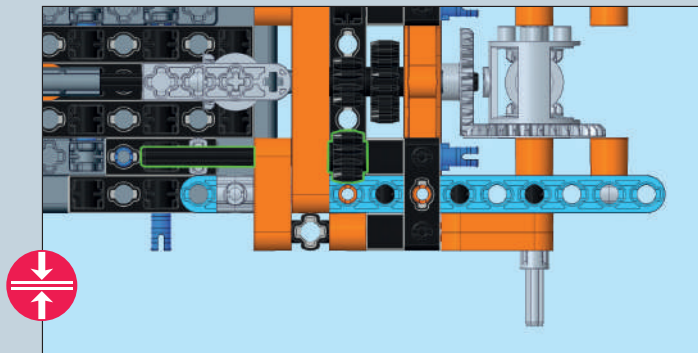
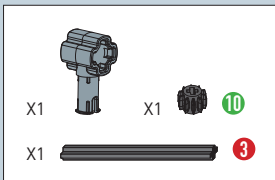
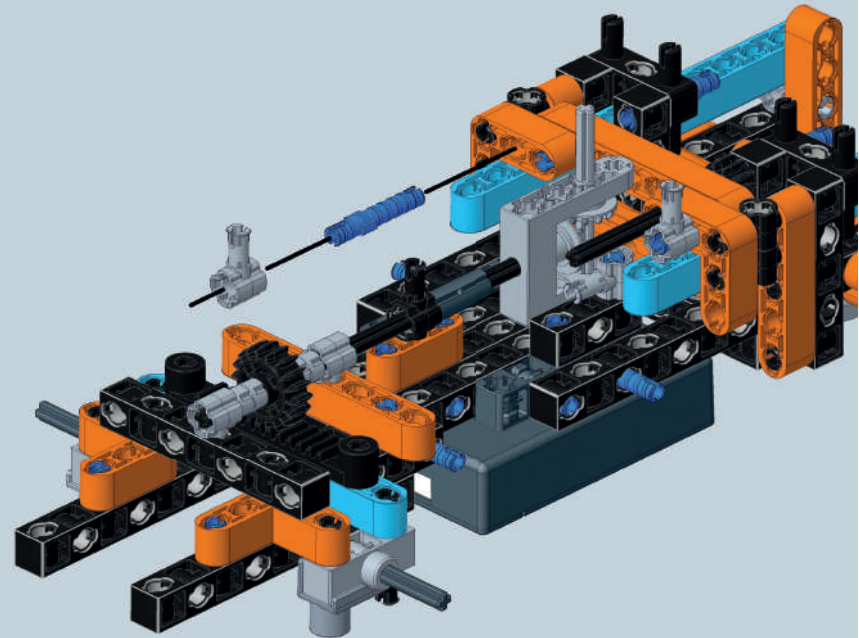
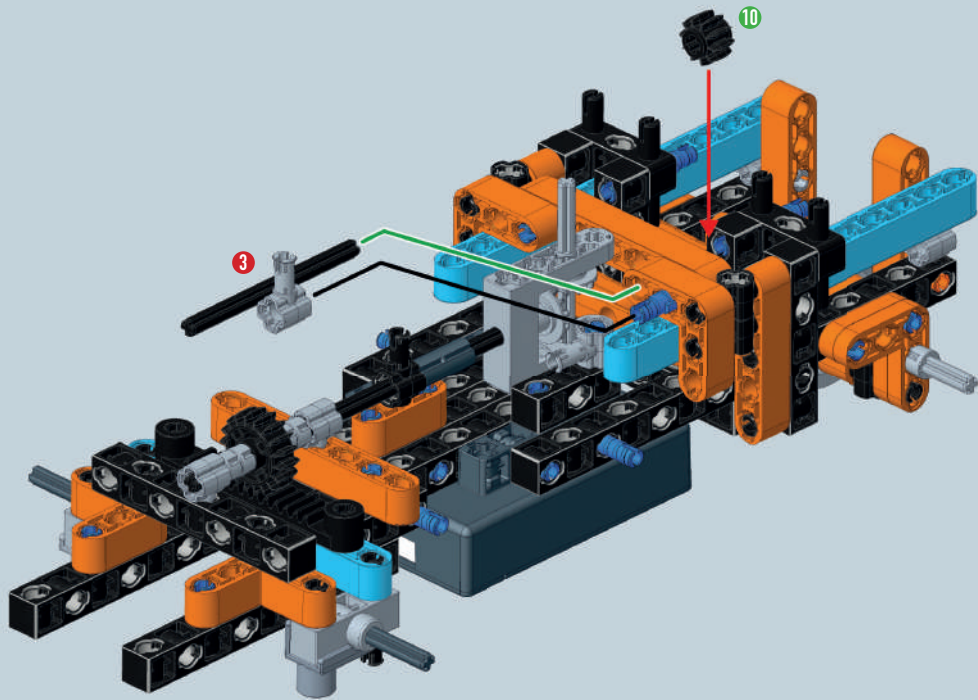

33

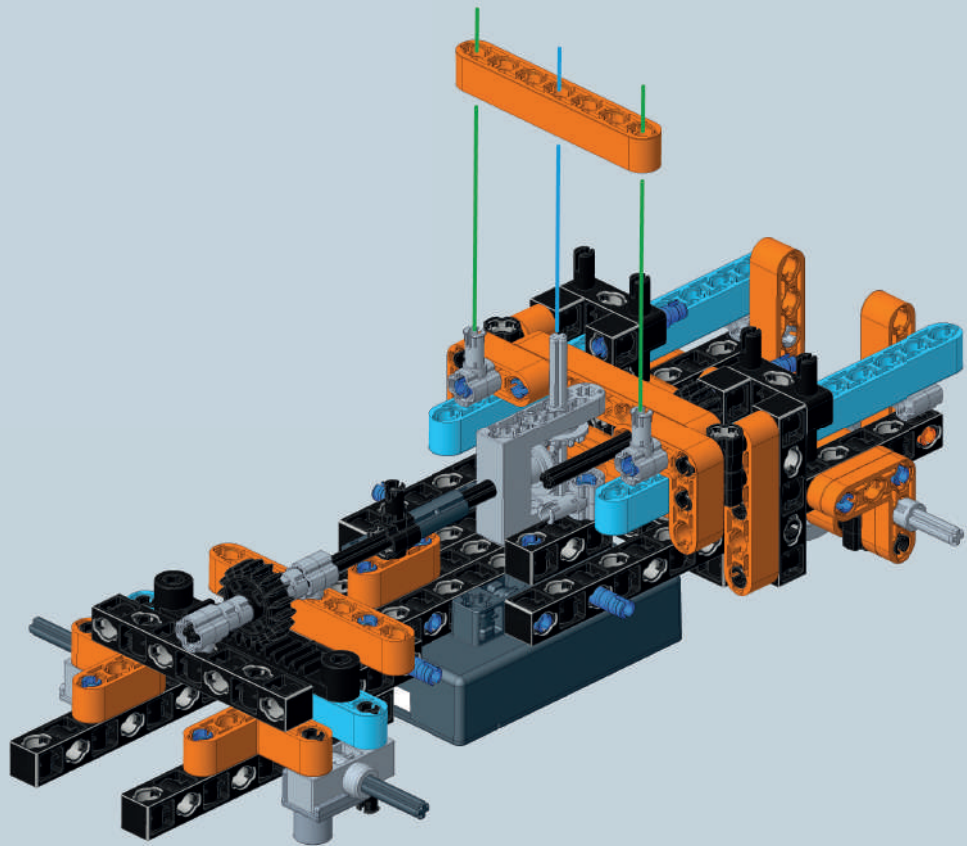

26

34

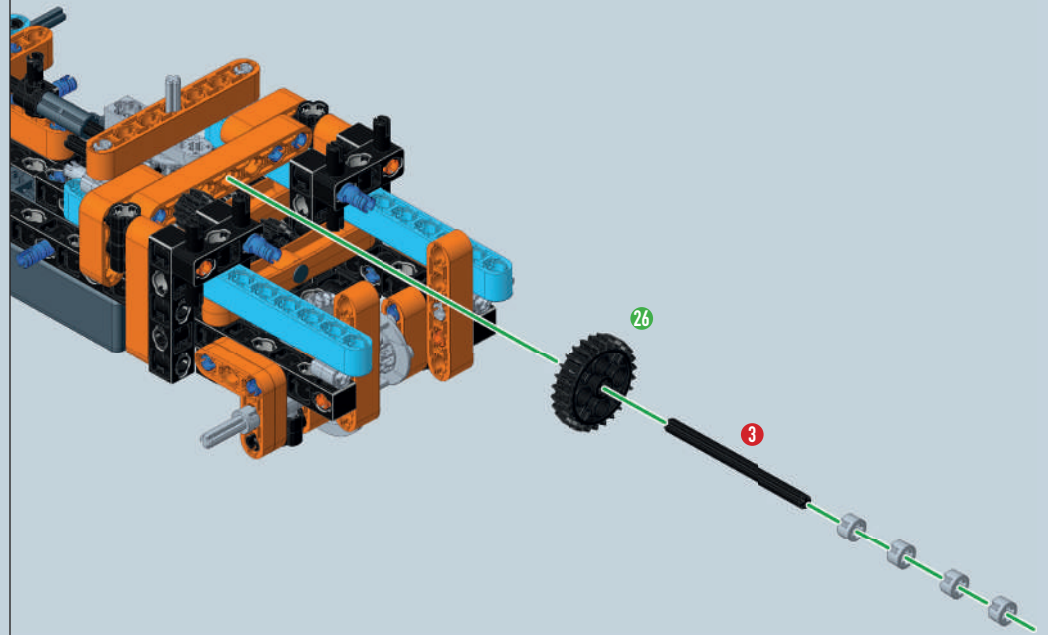

35

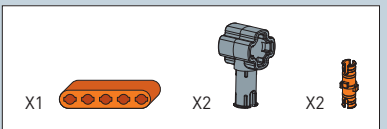
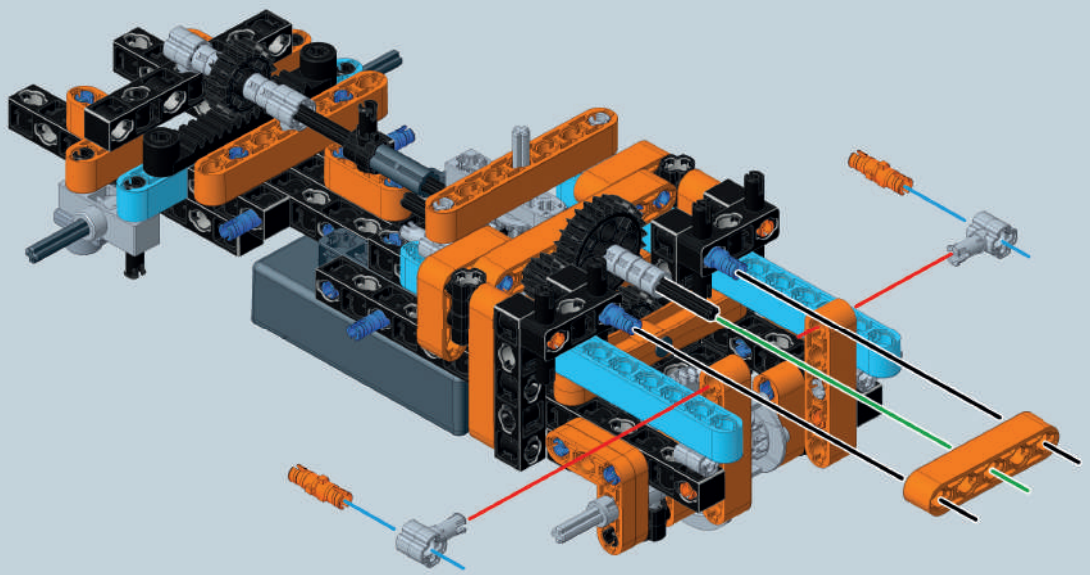

36

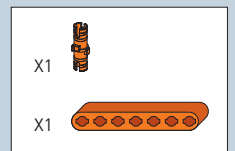
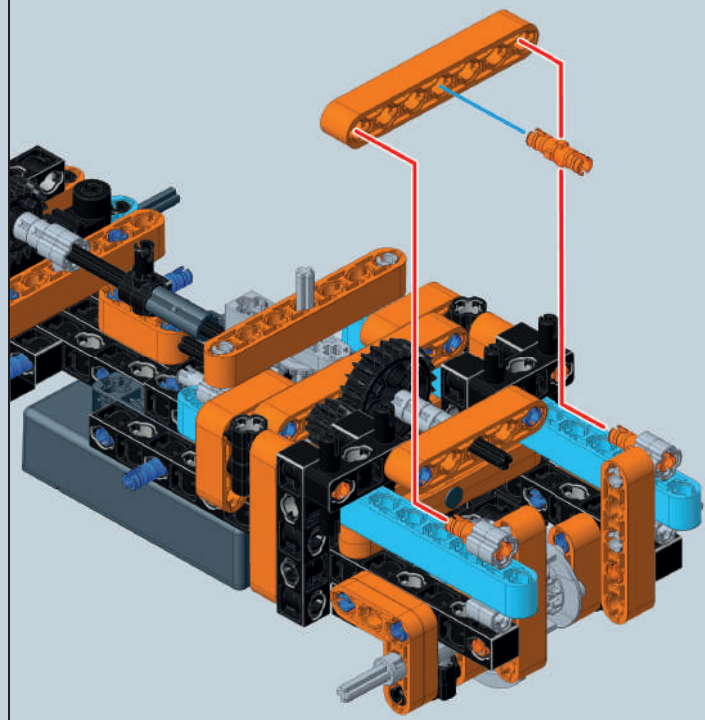

37

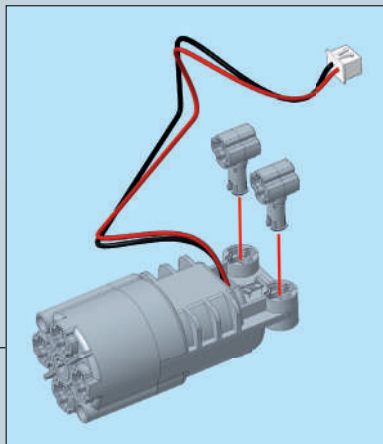
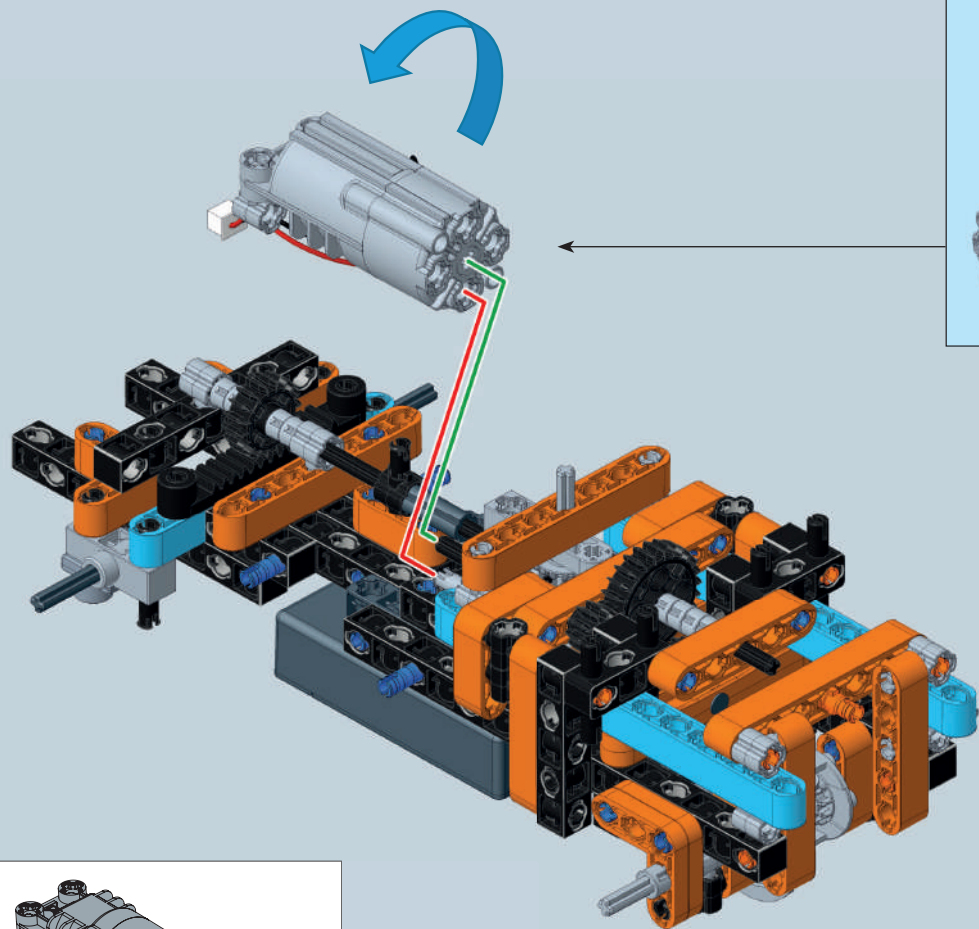

INTRODUCETI CABLUL MOTORULUI AȘA CUM SE ARATĂ ÎN SCHEMA ILUSTRATĂ

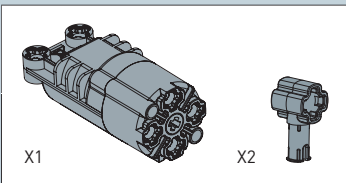
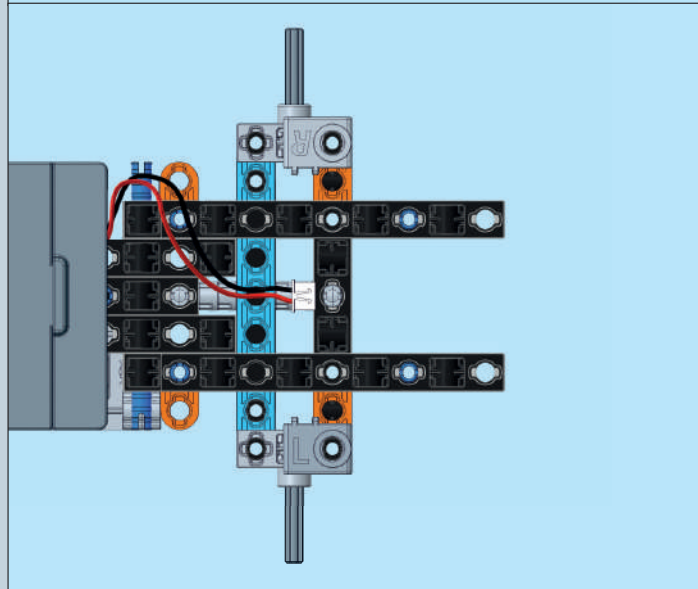
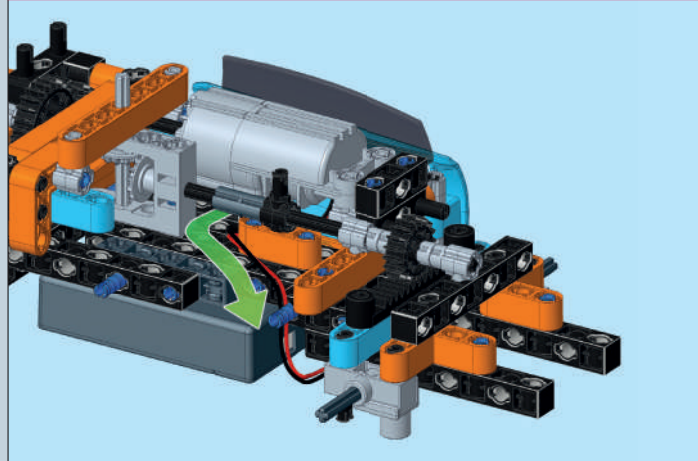

38

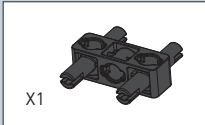
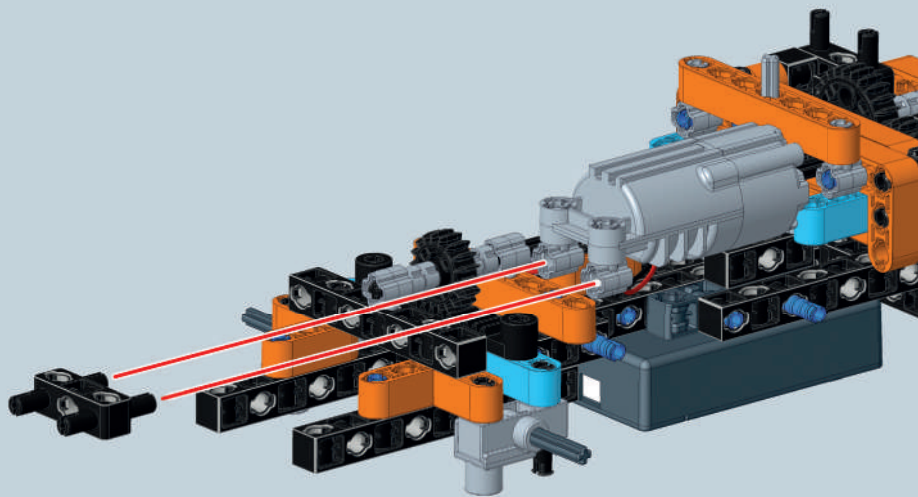

39

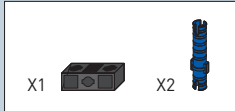
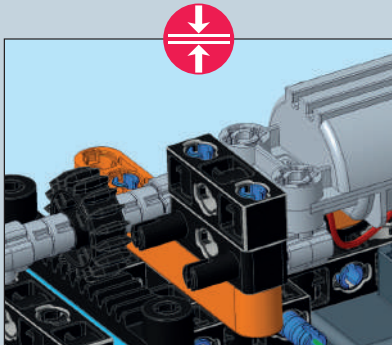
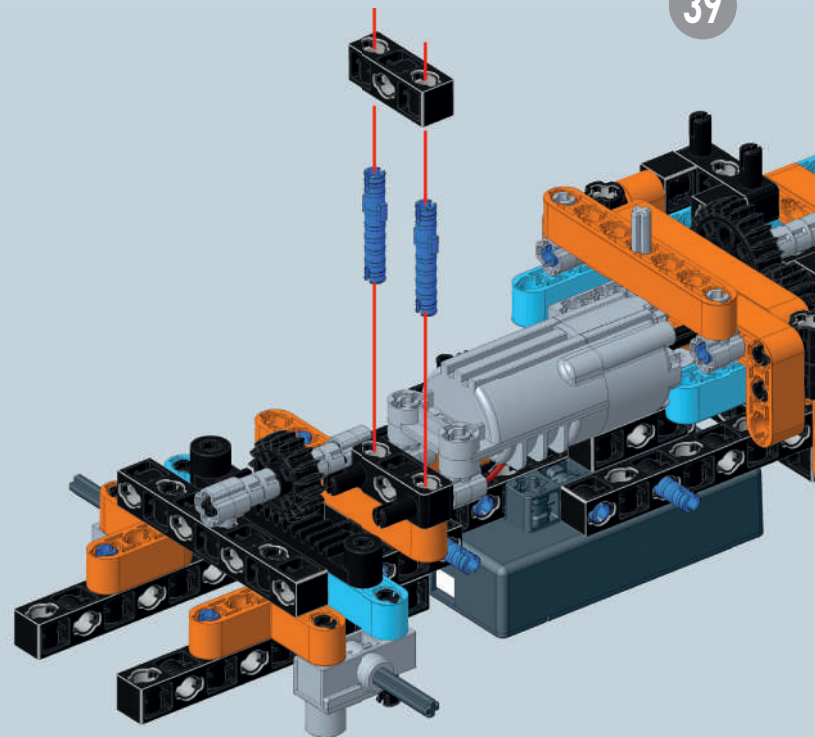

40

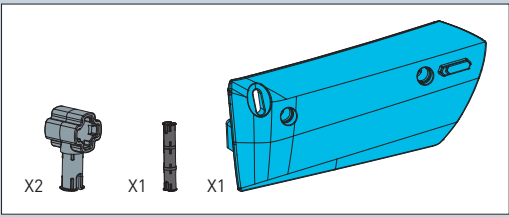
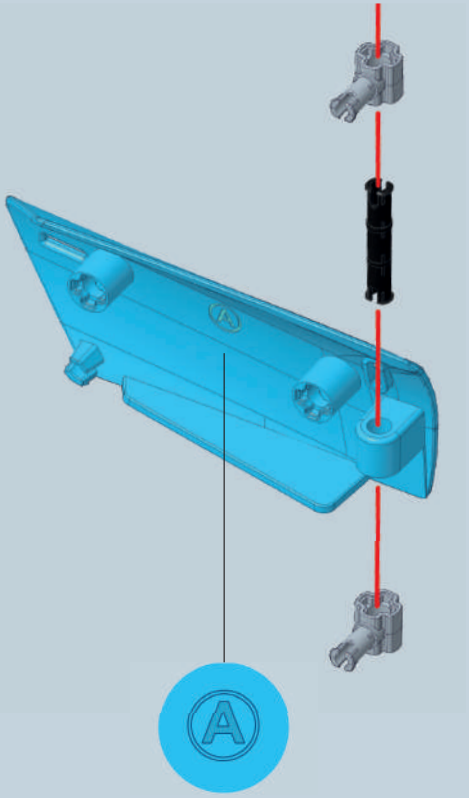

41

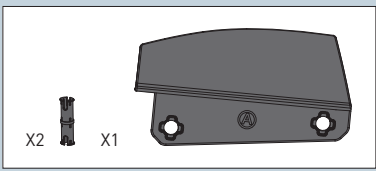
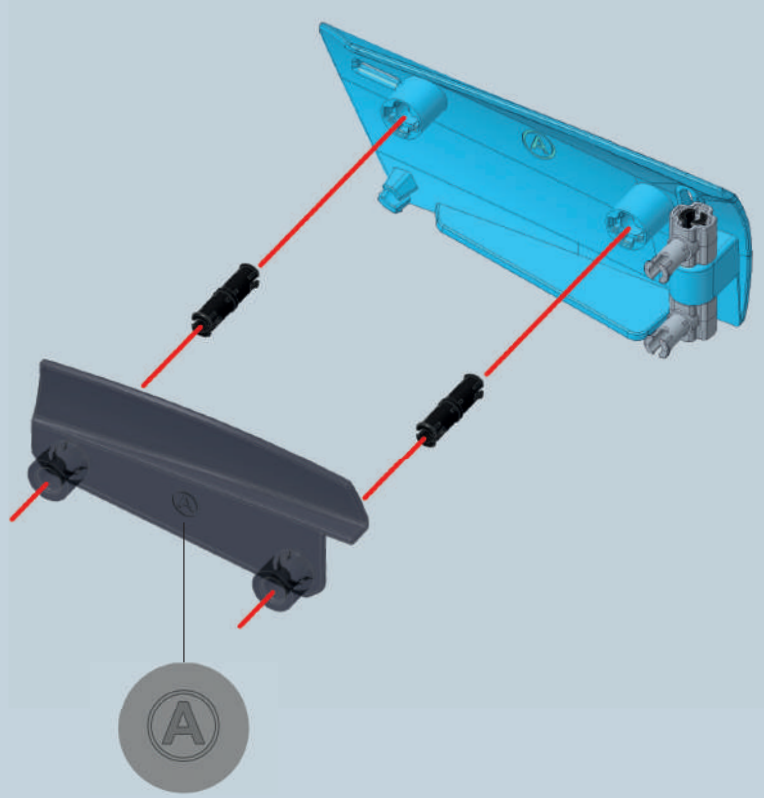

42

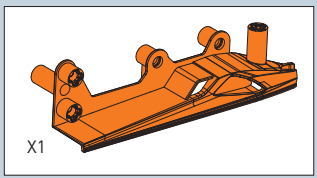
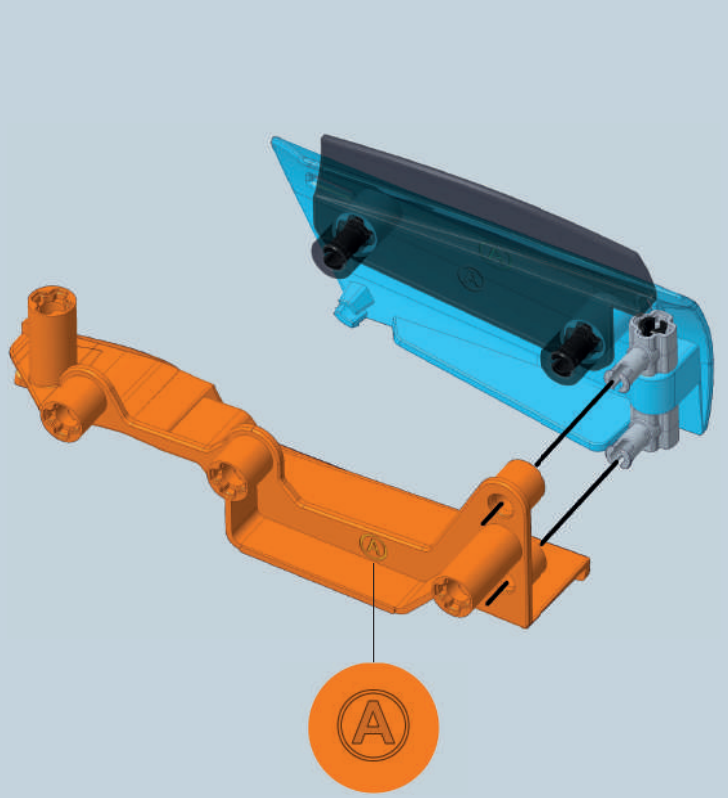

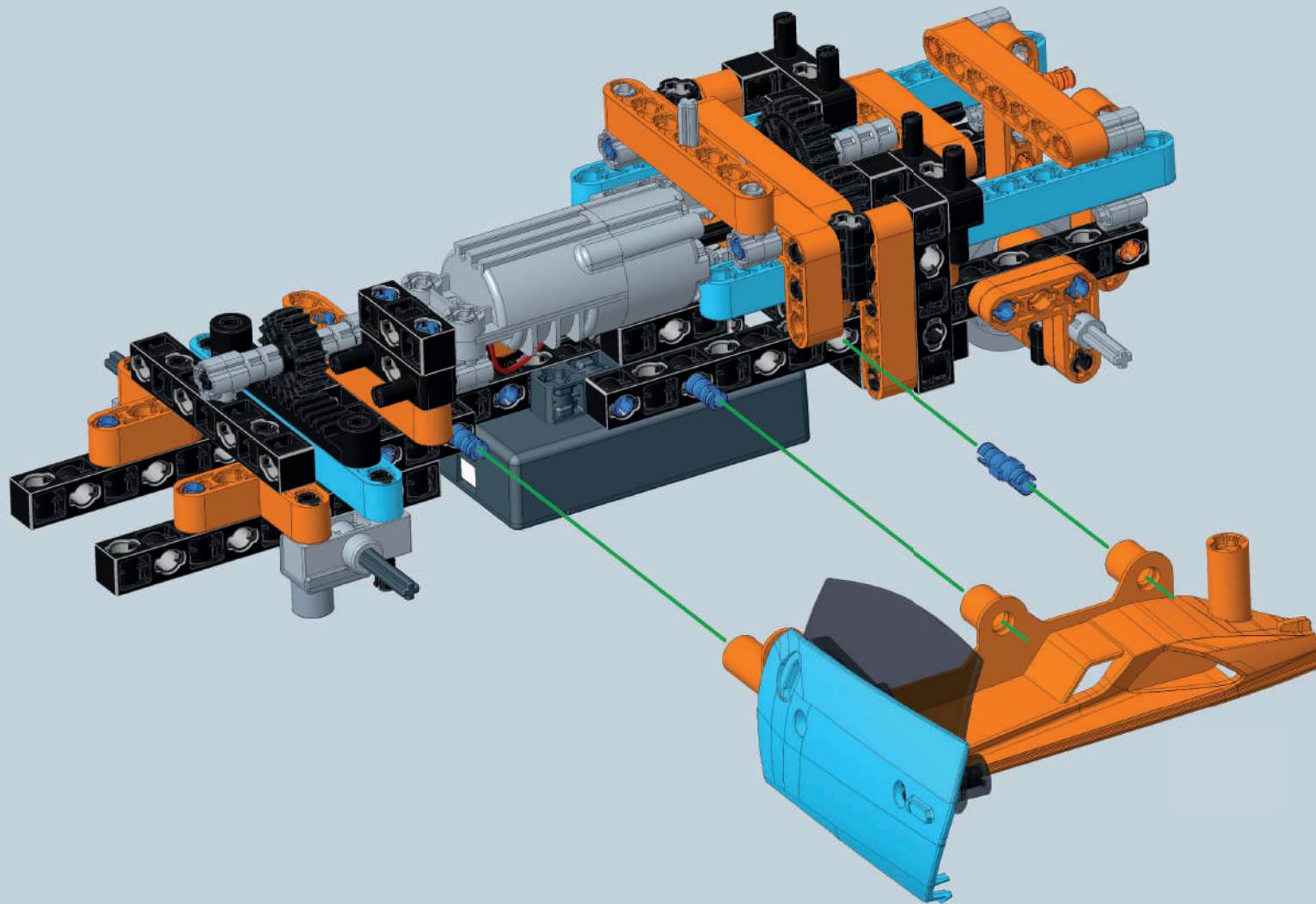

44

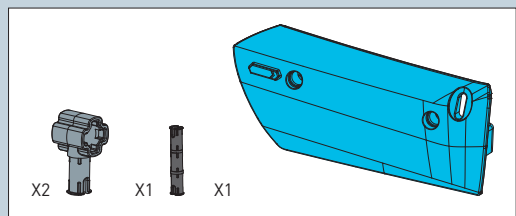
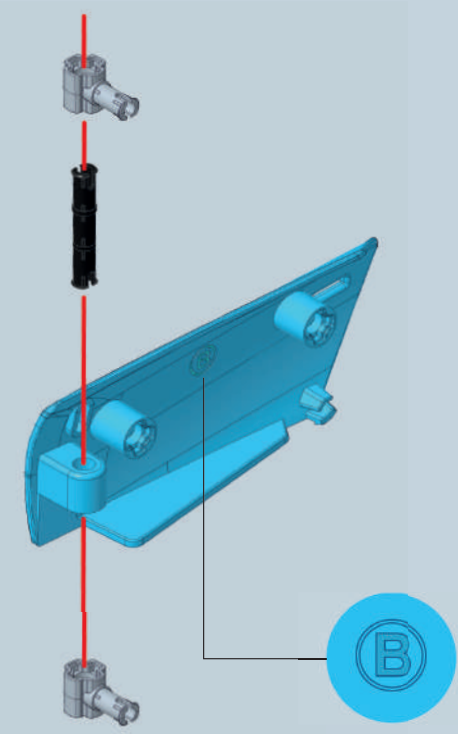

45

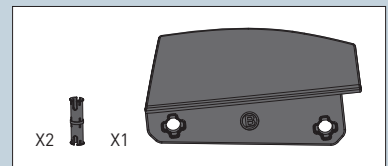
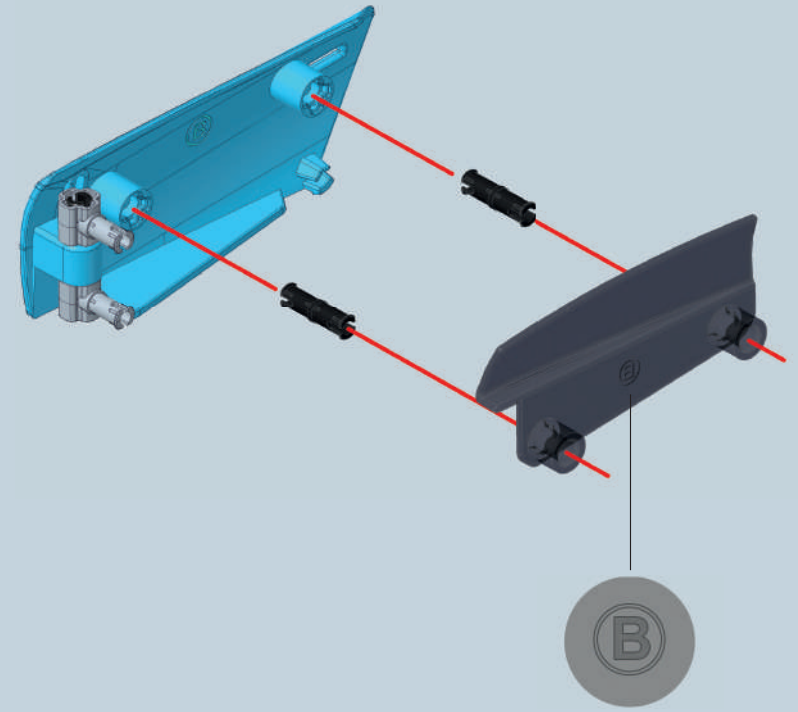

46

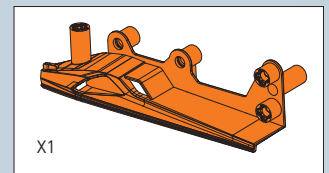
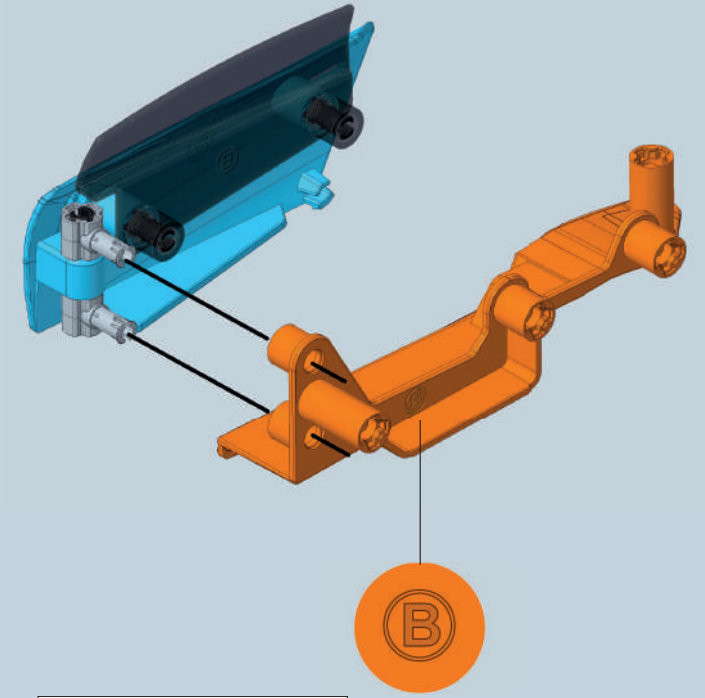

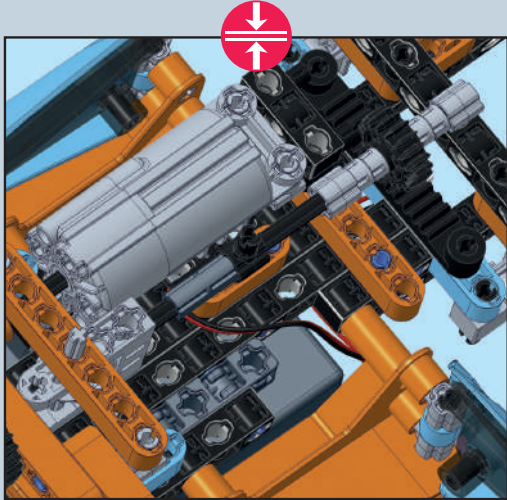
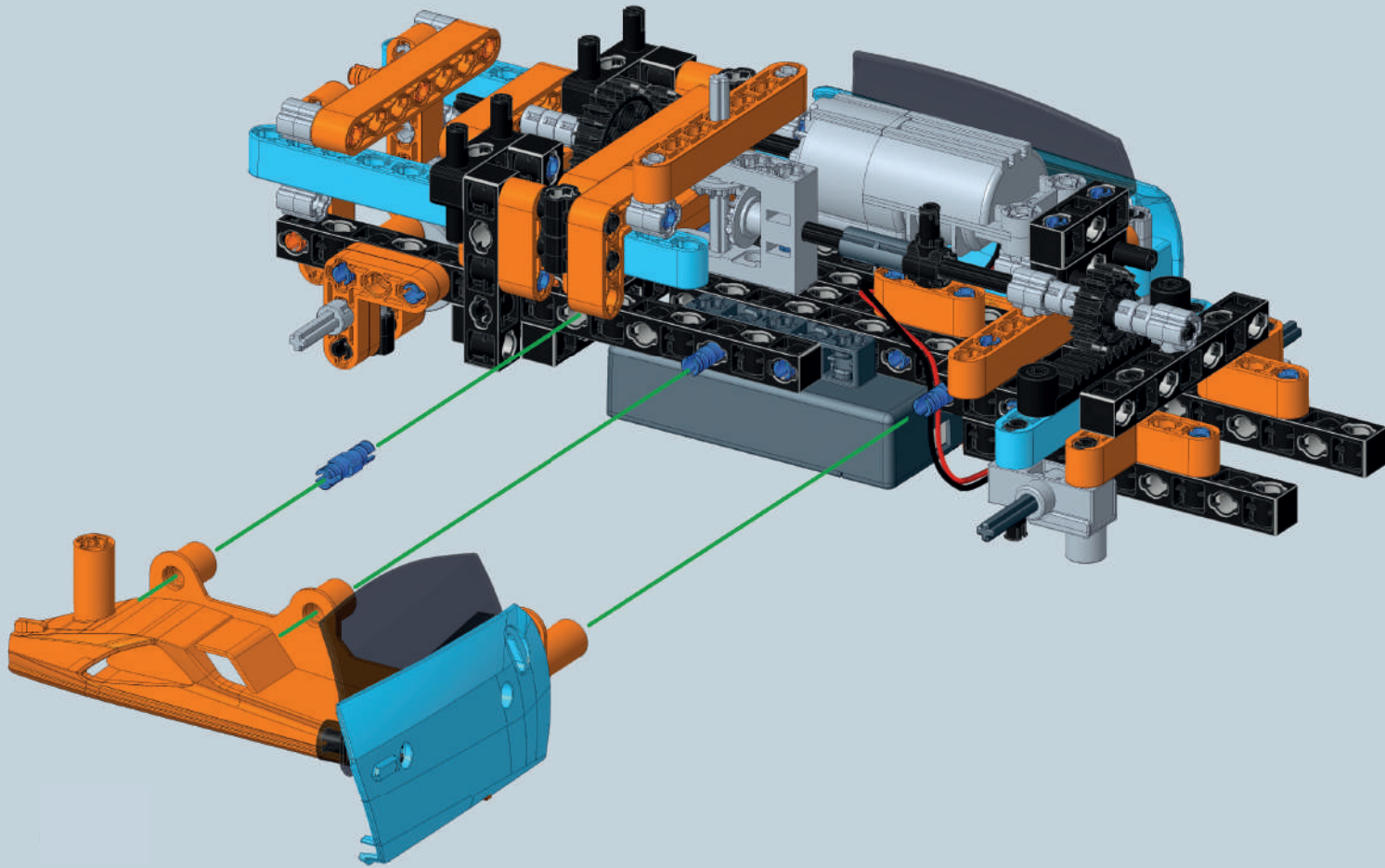

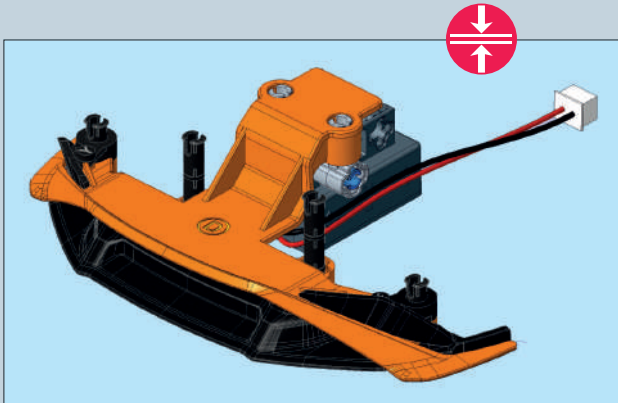
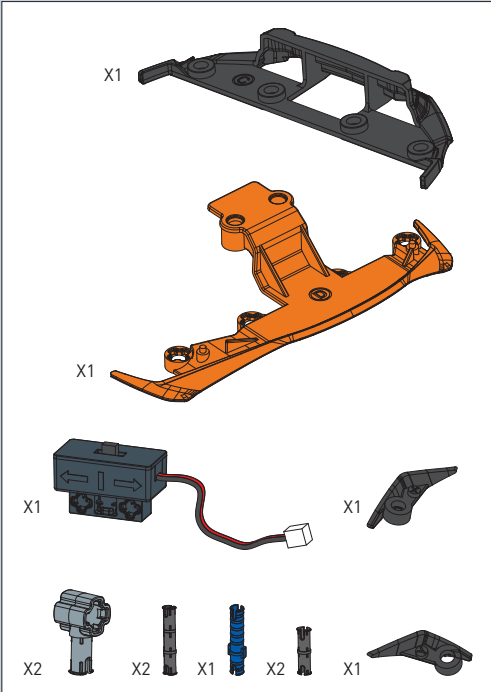
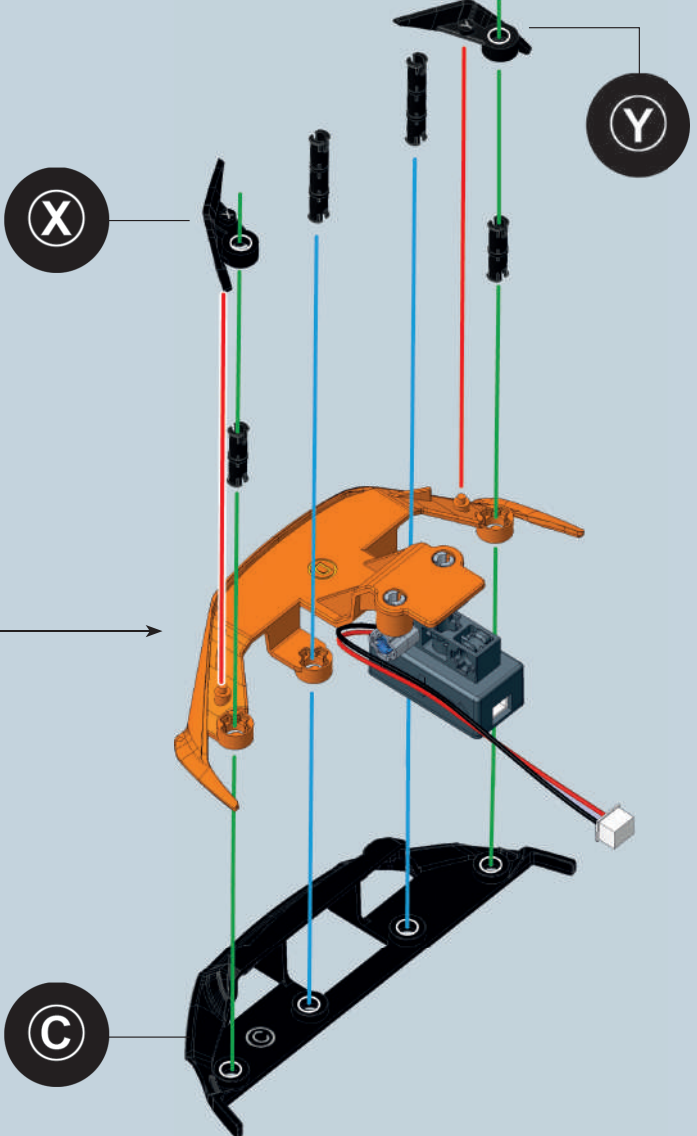
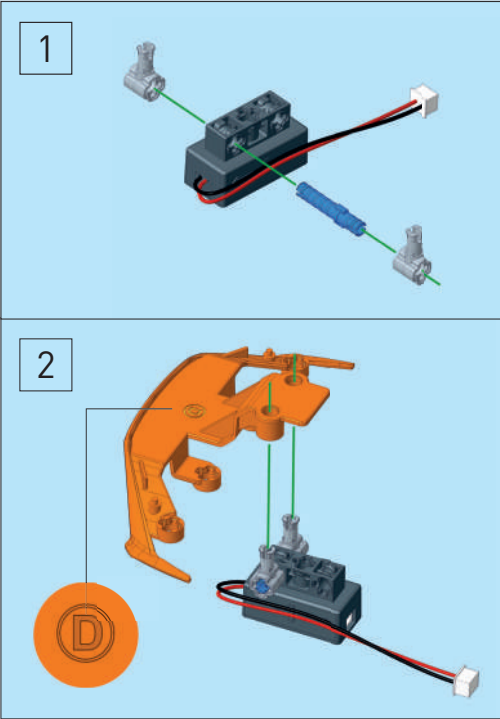

49

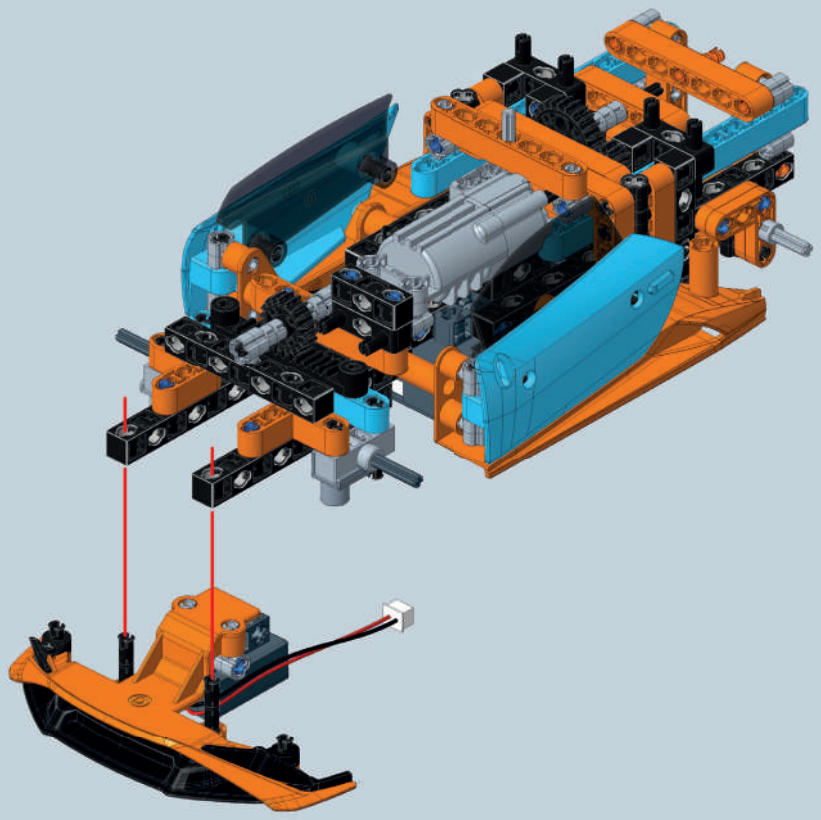

50

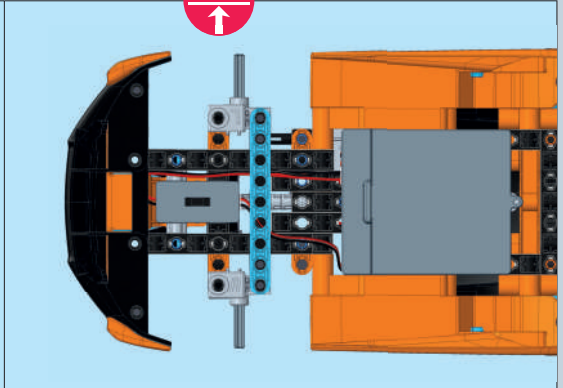
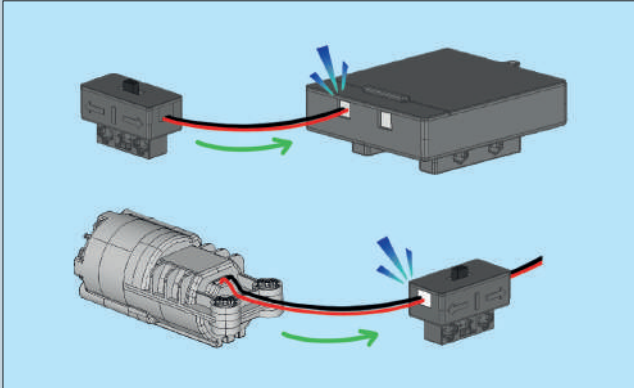
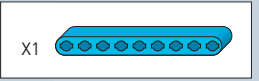
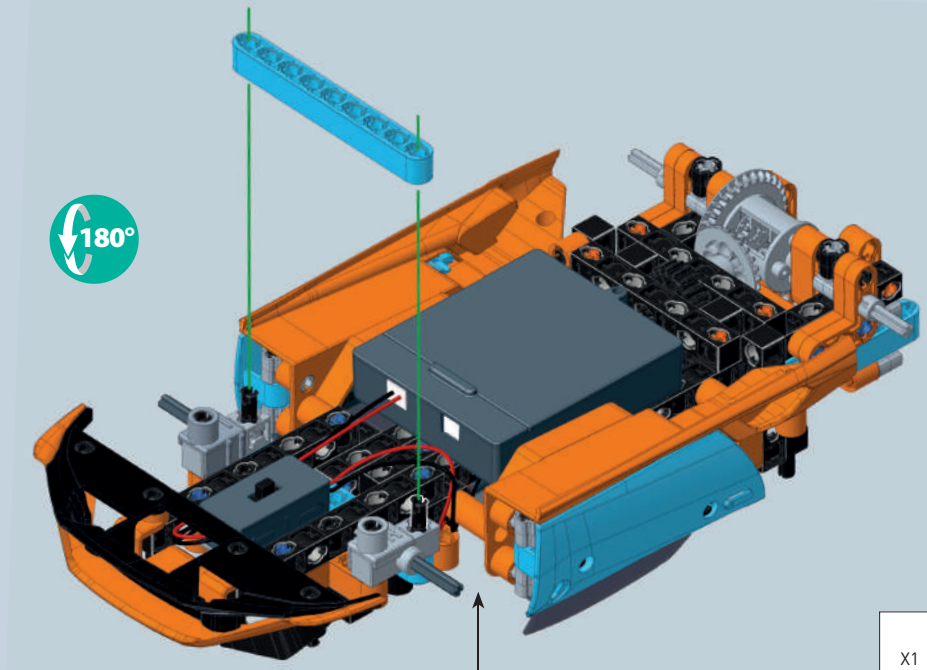

51

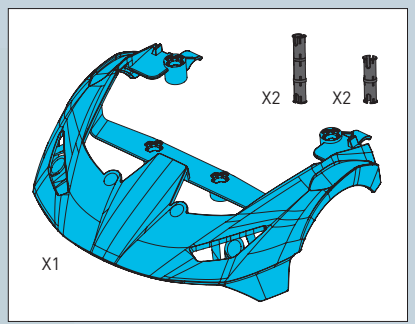
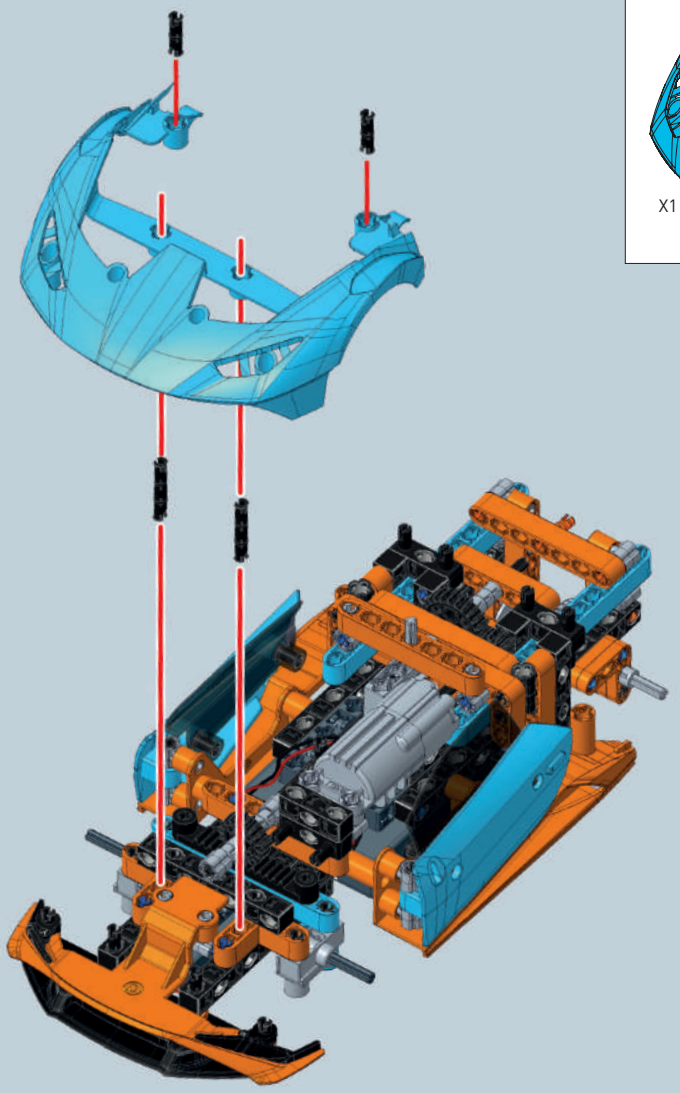

52

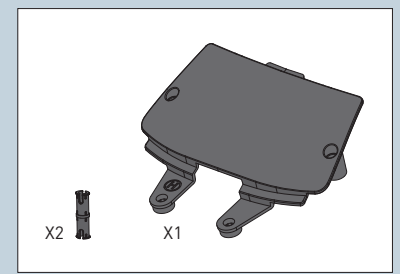
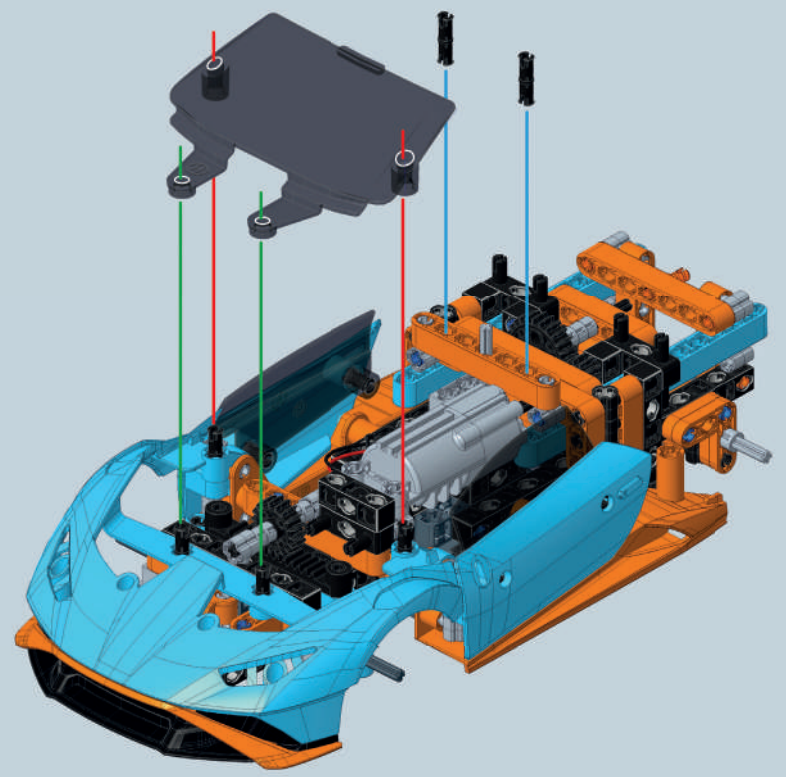

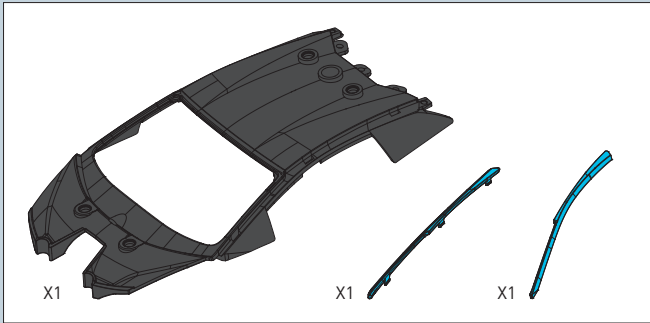

53

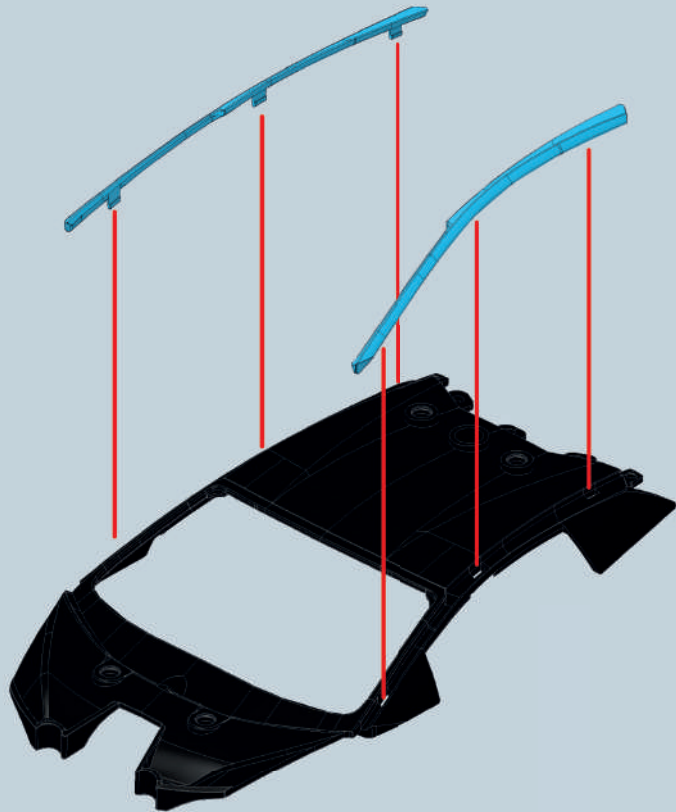

54

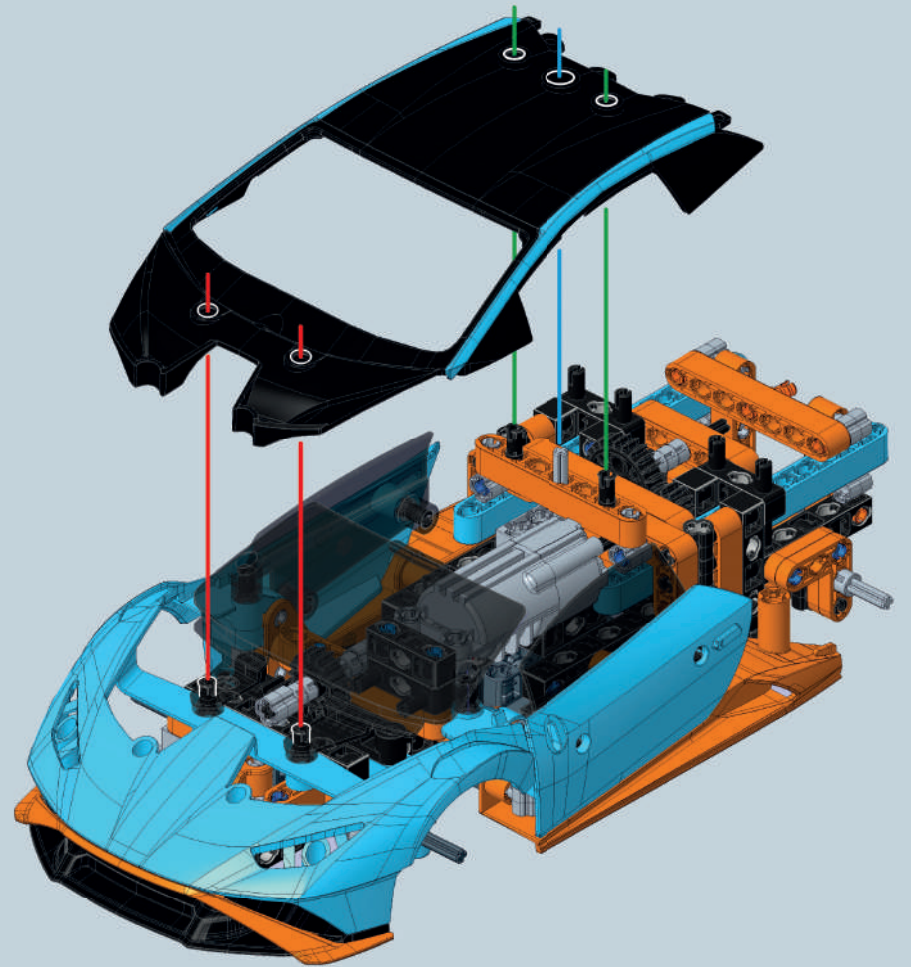



ÎMPINGEȚI PARBRIZUL DINSPRE
INTERIOR PENTRU A-L FIXA

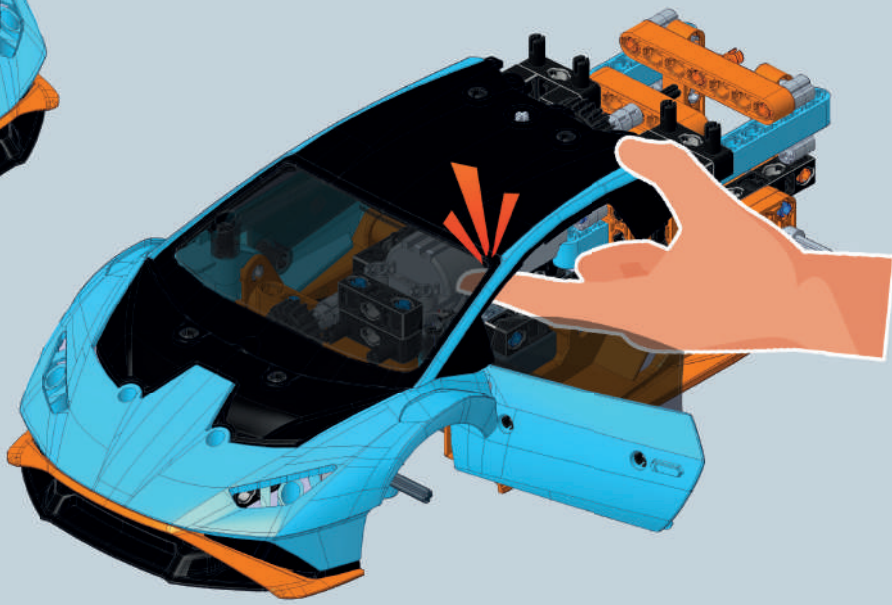

56

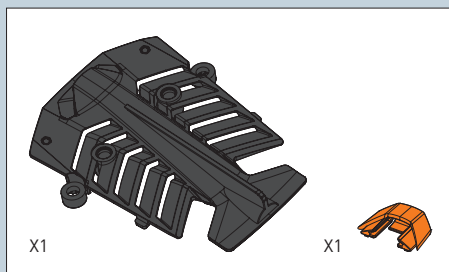
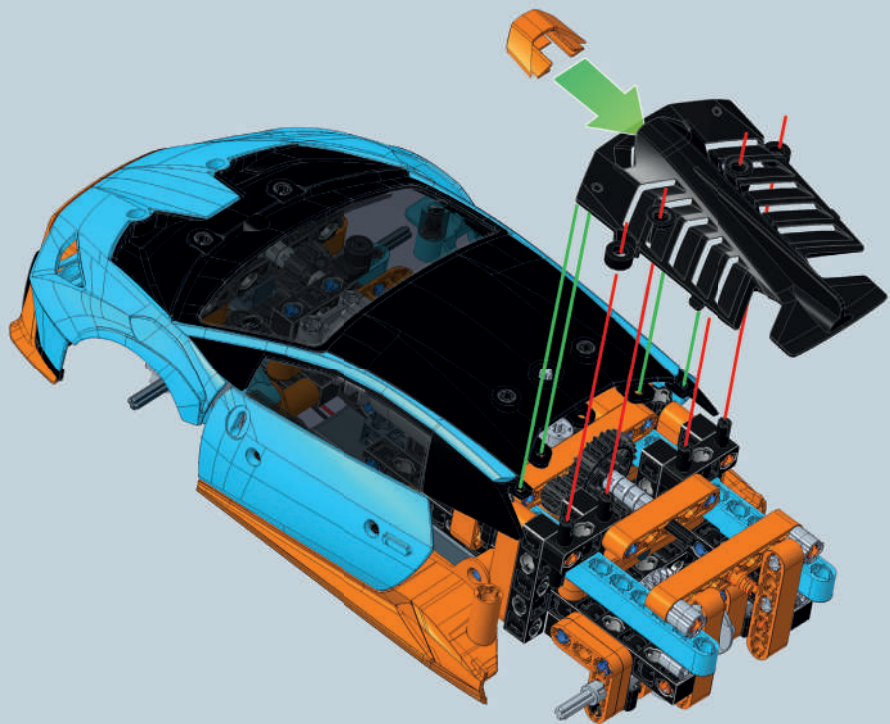

57

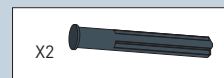
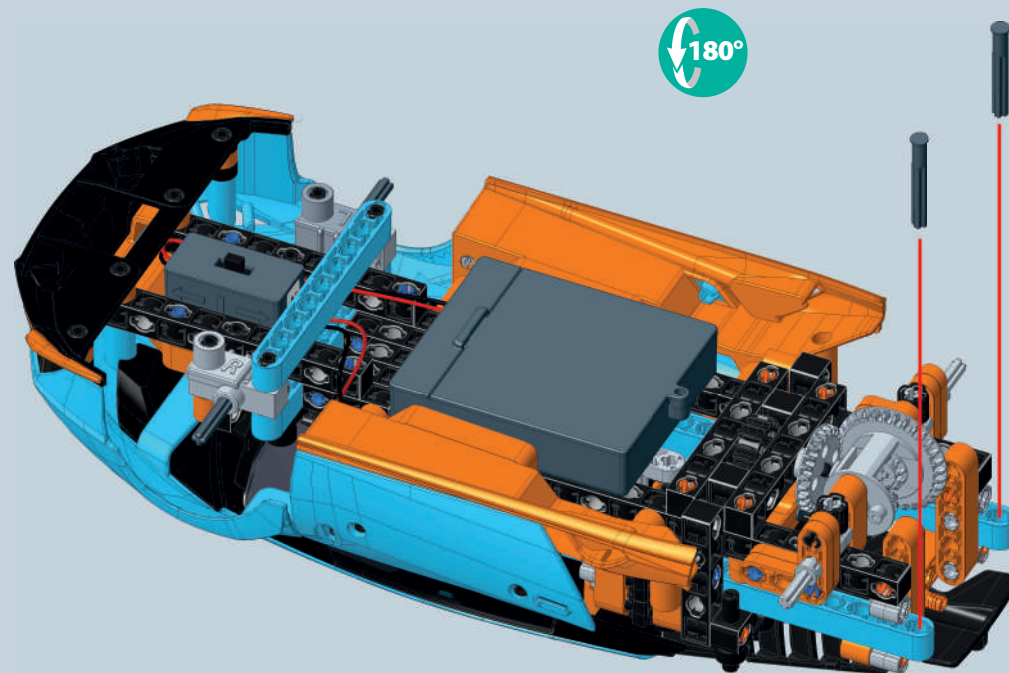

58

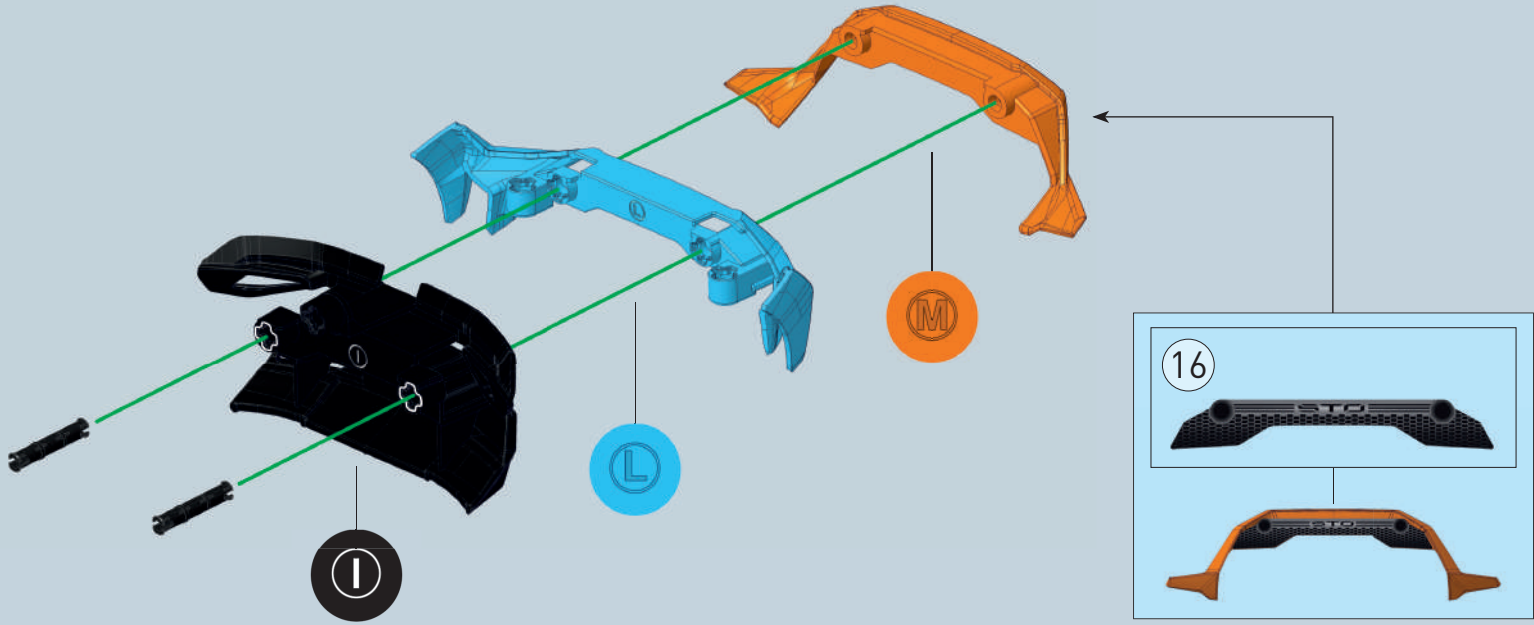
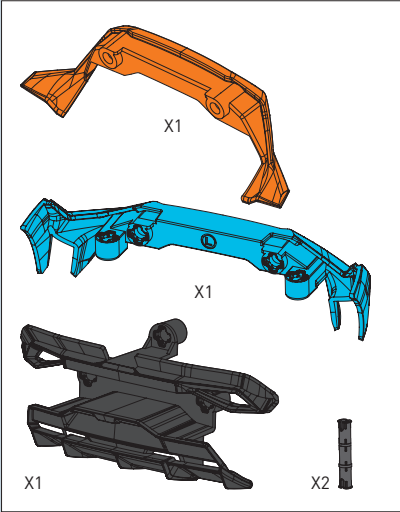

59

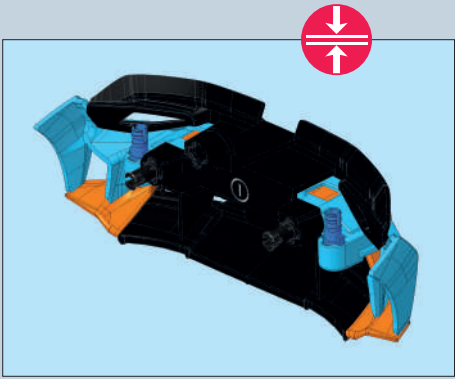
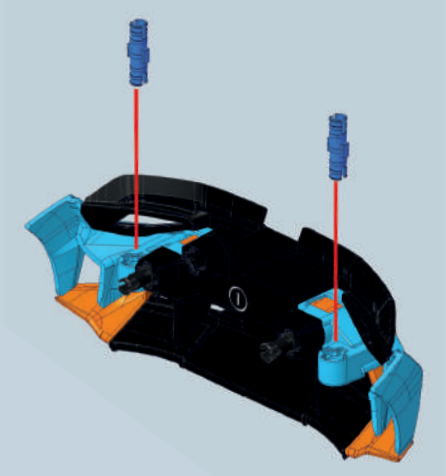

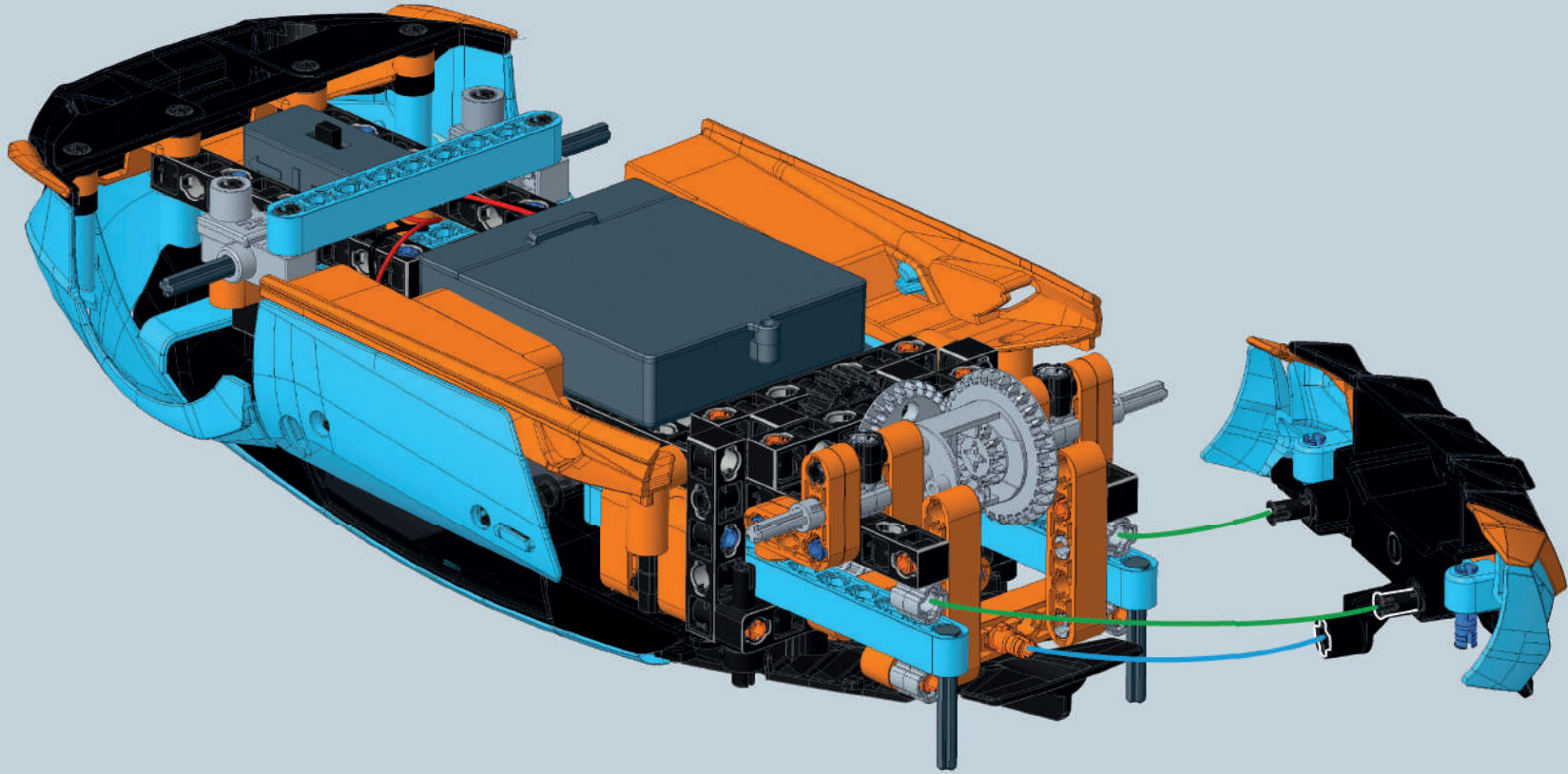

61

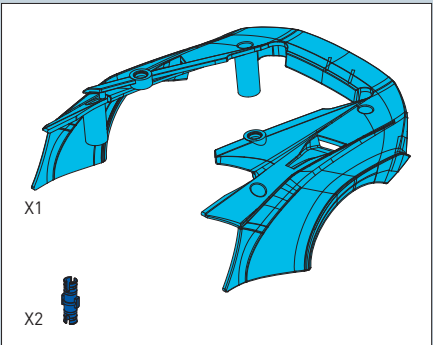
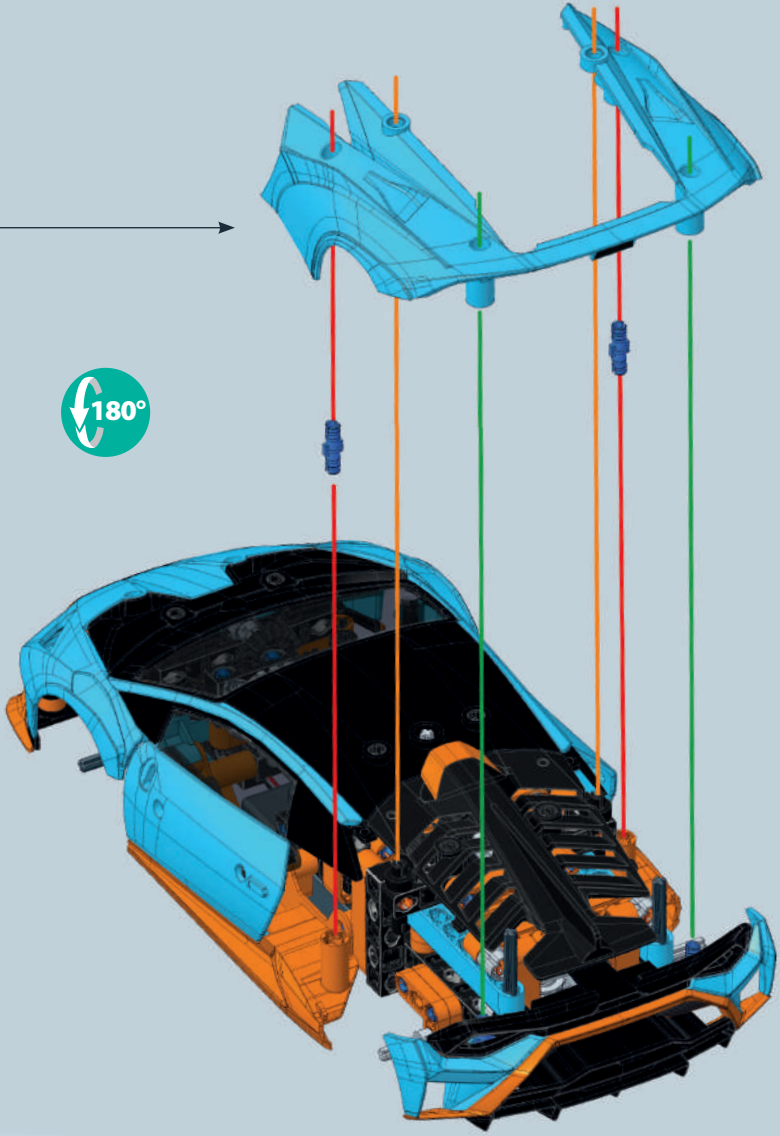
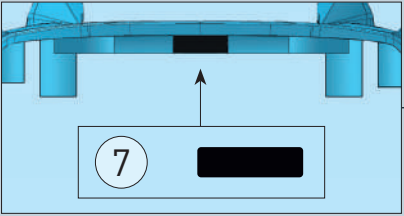

APĂSAȚI PE LATURI PE AMBELE PĂRȚI ALE MAȘINII, CA SĂ LE SECURIZAȚI SUB PARTEA NEAGRĂ A ACOPERIȘULUI.

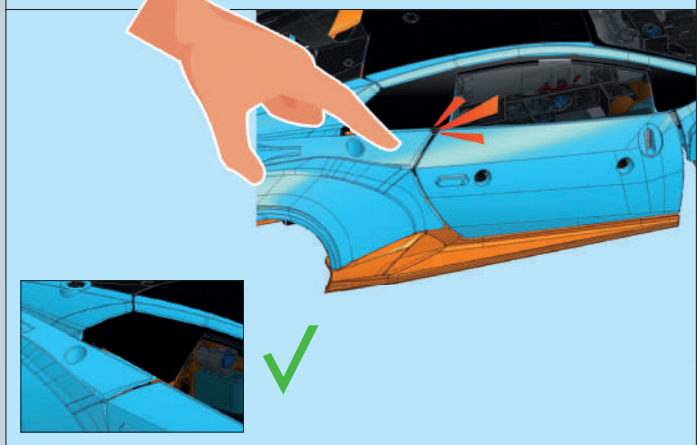
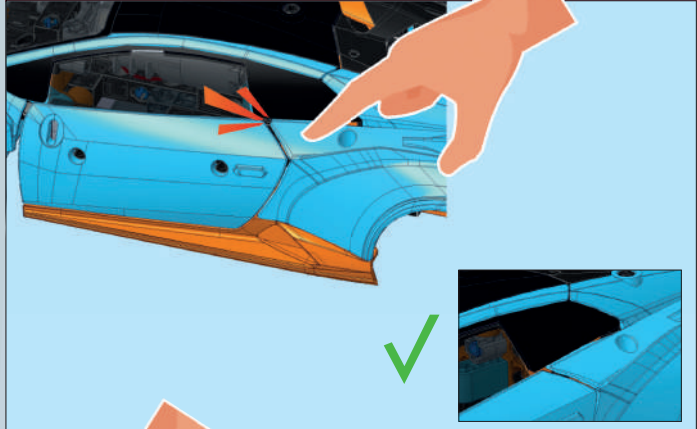

62

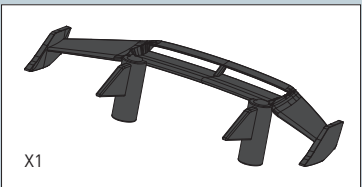
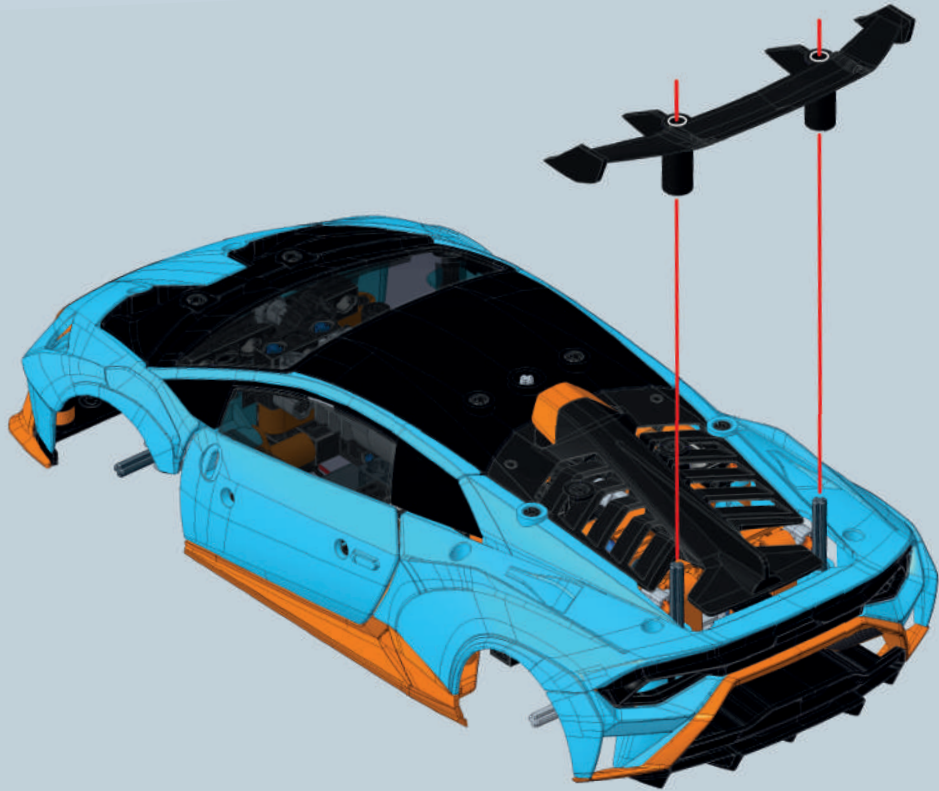

63

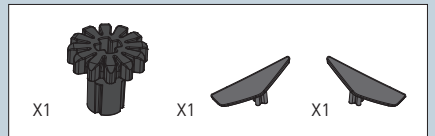
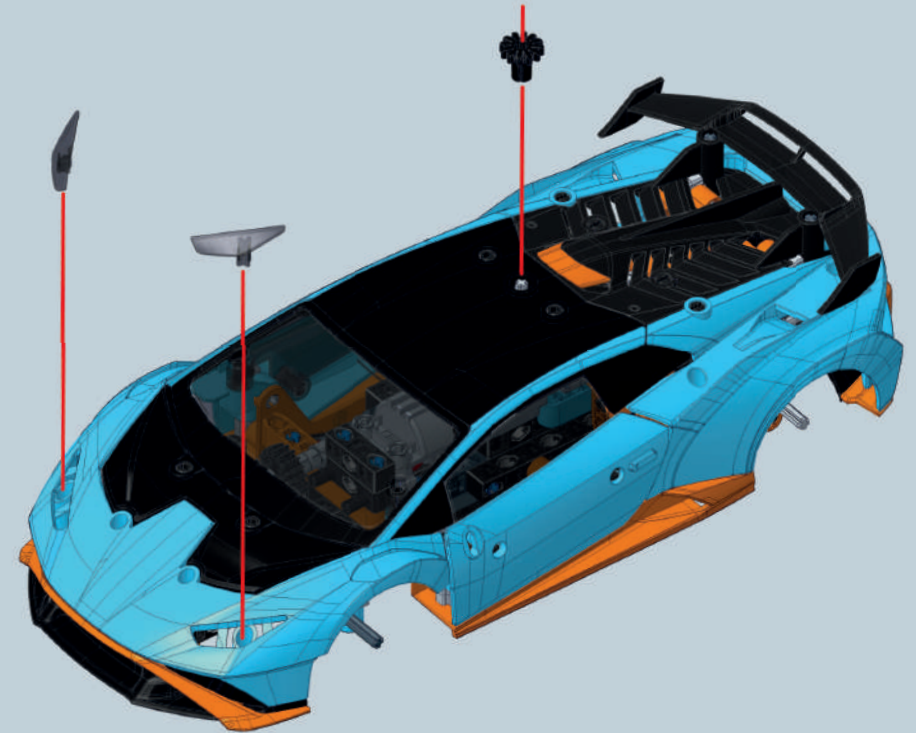

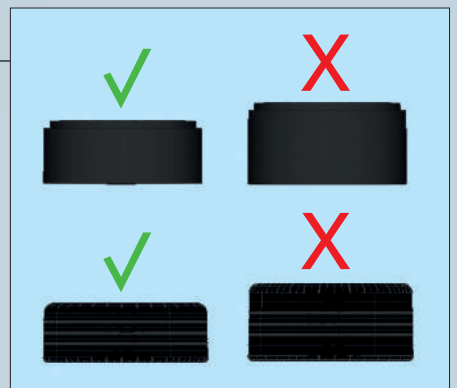
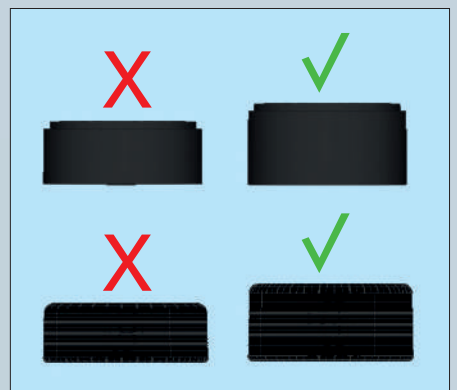
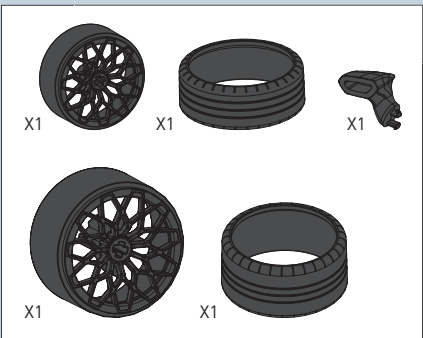
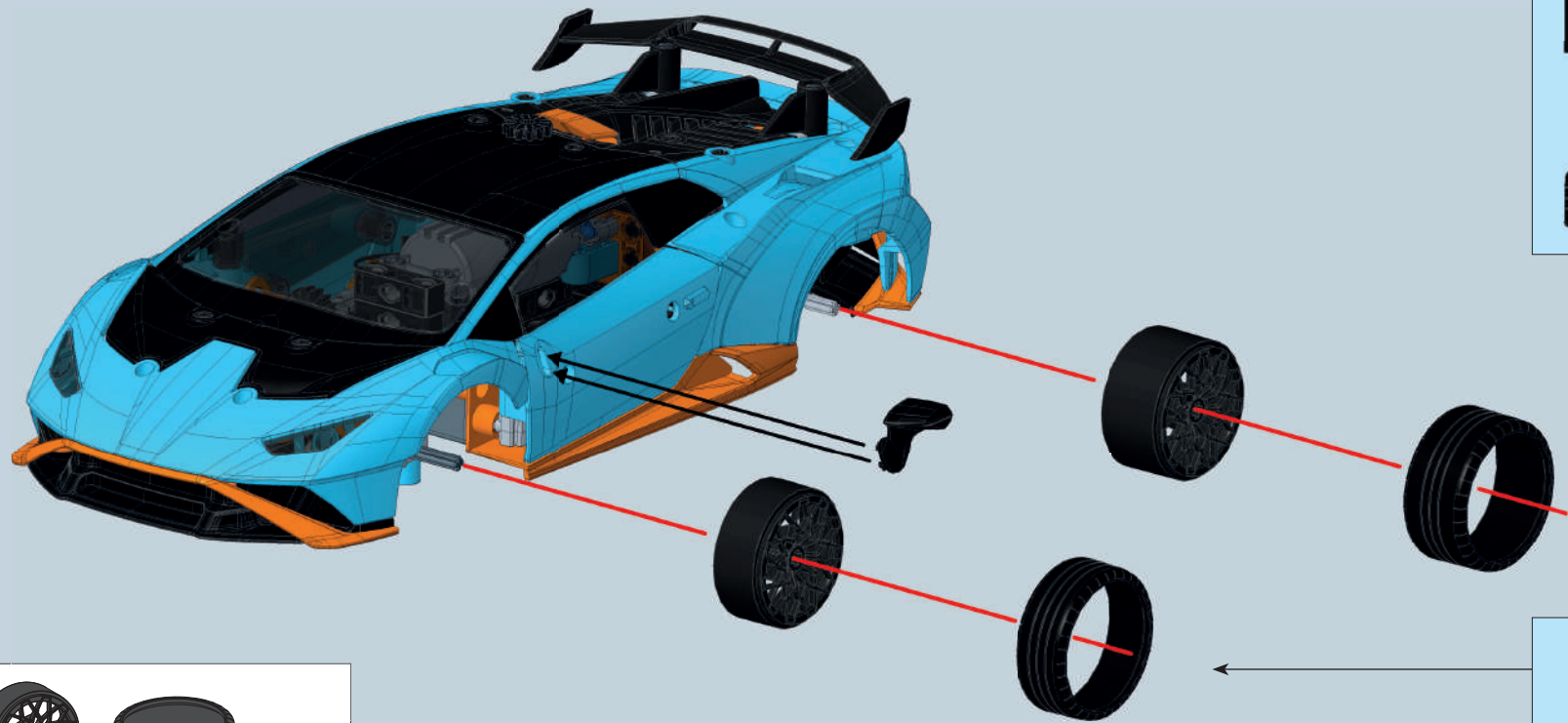

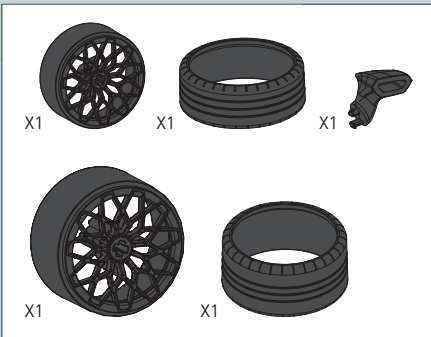
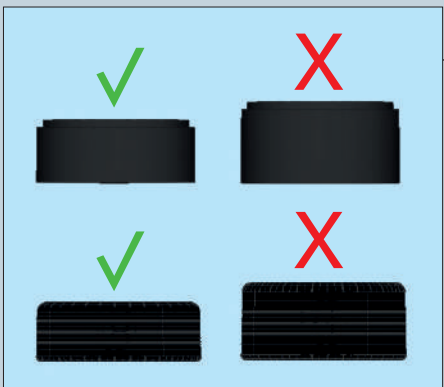
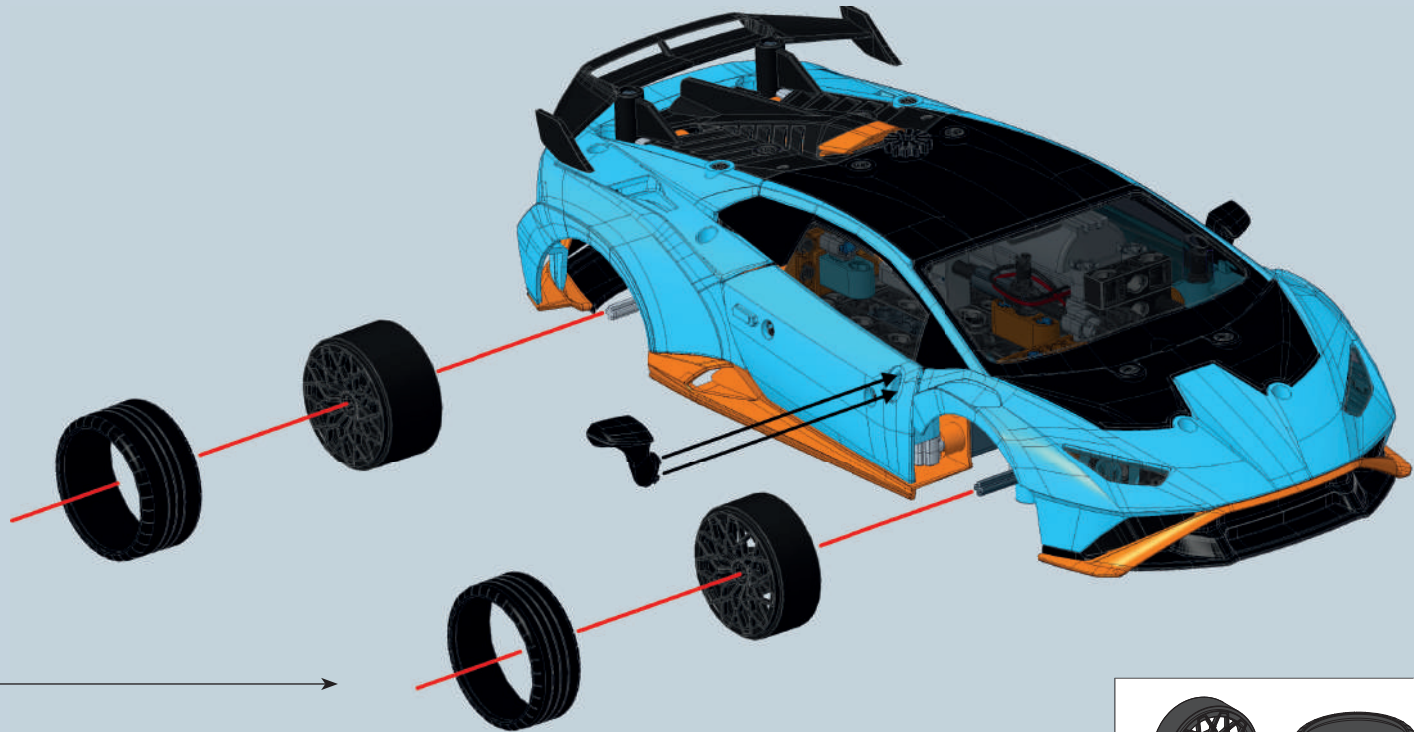
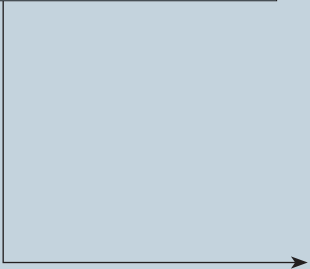
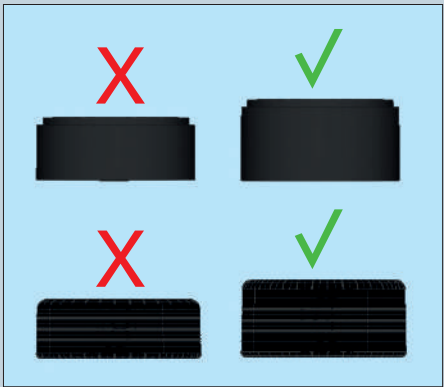

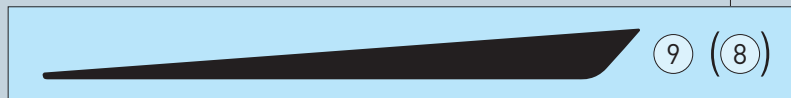
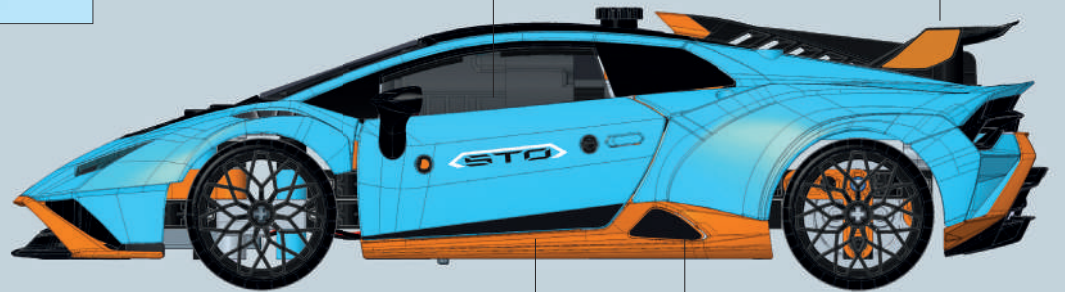
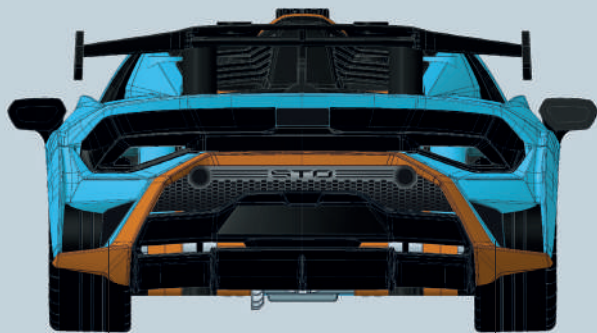
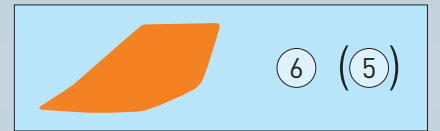
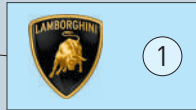
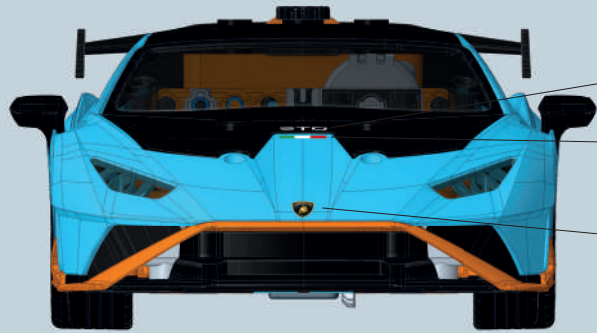

MOD MANUAL

Trageți în spate de spoiler: motorul nu va transmite mișcarea către roțile din spate, ca să puteți manevra mașina în modul manual.



MOD MOTORIZAT

Împingeți spoilerul în față: motorul va transmite mișcarea către roțile din spate, ca să puteți manevra mașina în modul motorizat.



Schimbați poziția selectorului pentru a face mașina să se deplaseze în față sau în spate.

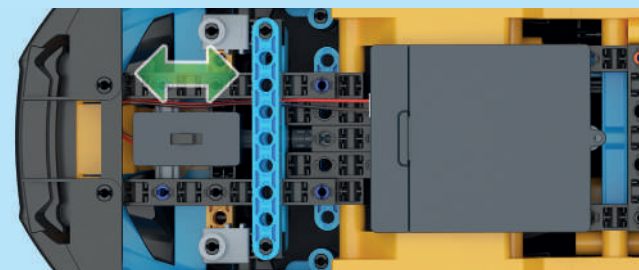

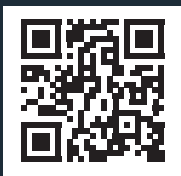
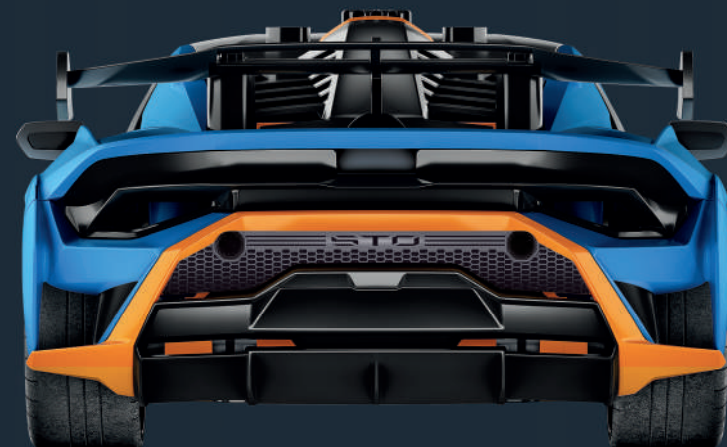
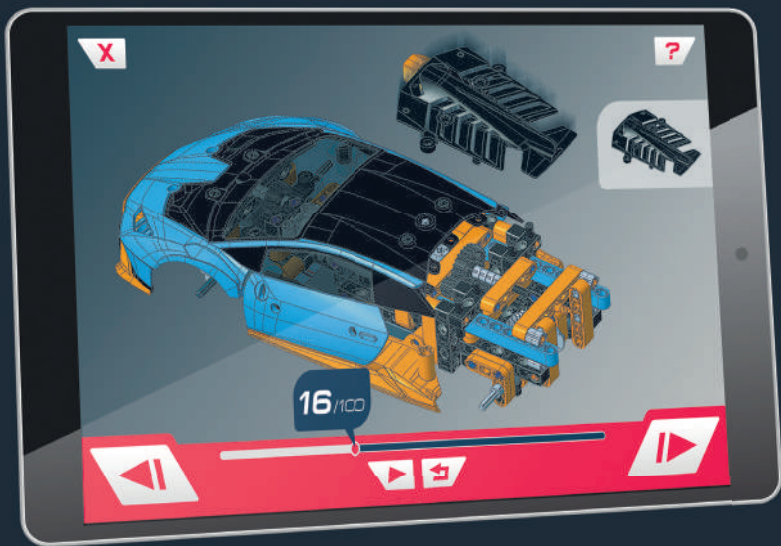

Descarcă gratuit aplicația
Science & Play BUILD.

Animațiile interactive vă
ghidează în procesul de
asamblare a **10 modele
fantastice**, într-un mod
simplu și rapid.

COMPATIBILITATEA APLICAȚIEI

Aplicația este
compatibilă cu
ANDROID™, APPLE®
și **AMAZON®**.

Nu este compatibilă
cu sistemul de
operare **WINDOWS®**.



Descărcăți de pe
App Store
Apple și sigla Apple sunt mărci
înregistrate ale Apple Inc.,
înregistrate în S.U.A. și alte țări. App
Store este un serviciu marca Apple
Inc., înregistrat în S.U.A. și în alte țări.



DESCARCĂ DE PE
Google Play
Google Play și sigla Google Play sunt
mărci înregistrate ale Google LLC.



available at
amazon appstore
Amazon și toate siglele aferente sunt
mărci înregistrate ale Amazon.com,
Inc. sau ale afiliaților.



**Siglele „Lamborghini”, taurul și scutul sunt
mărci înregistrate, folosite sub licență de la
Automobili Lamborghini S.p.A., Italia.**