

Science
& play®

CONSTRUIEȘTE

V99577

MECANICA

ELICOPTERELOR DE SALVARE MONTANĂ



ATENȚIE! Setul este destinat numai copiilor cu vârsta mai mare de 8 ani. Setul include instrucțiuni pentru adulți, care trebuie citite și urmate.

ATENȚIE: pentru a asigura funcționarea adecvată a motorului electric, o cantitate mică de ulei a fost adăugată în timpul producției. În cazul unor temperaturi ridicate, este posibil ca această substanță să se topească și să devină uleioasă. Dacă motorul din set este murdar, curățați-l folosind șervețele de hârtie. Uleiul folosit nu este toxic sau periculos.

Citiți și păstrați instrucțiunile pentru referințe ulterioare.



SUNMAN SAN. MAM. ITH. IHR. VE TIC. A.S.
Centrul Logistic Sunman, Strada Turgut Özal nr. 125
Cayirova 41420 KOCAELI, TURCIA
Tel.: +90 216 499 80 80; Fax: +90 216 314 67 20
www.sunman.com.tr; info@sunman.com.tr

Importator:
S.C. INTERTOY ZONE S.R.L.
București, Sector 2, Strada Căminului nr. 6
Tel.: 021 405 06 09

Producător:
Clementoni S.p.A.
Zona Industriale Fontenoce s.n.c.
62019 Recanati (MC) - Italy
Tel.: +39 071 75811
www.clementoni.com
<https://www.clementoni.com/en/form>

 **Clementoni®**

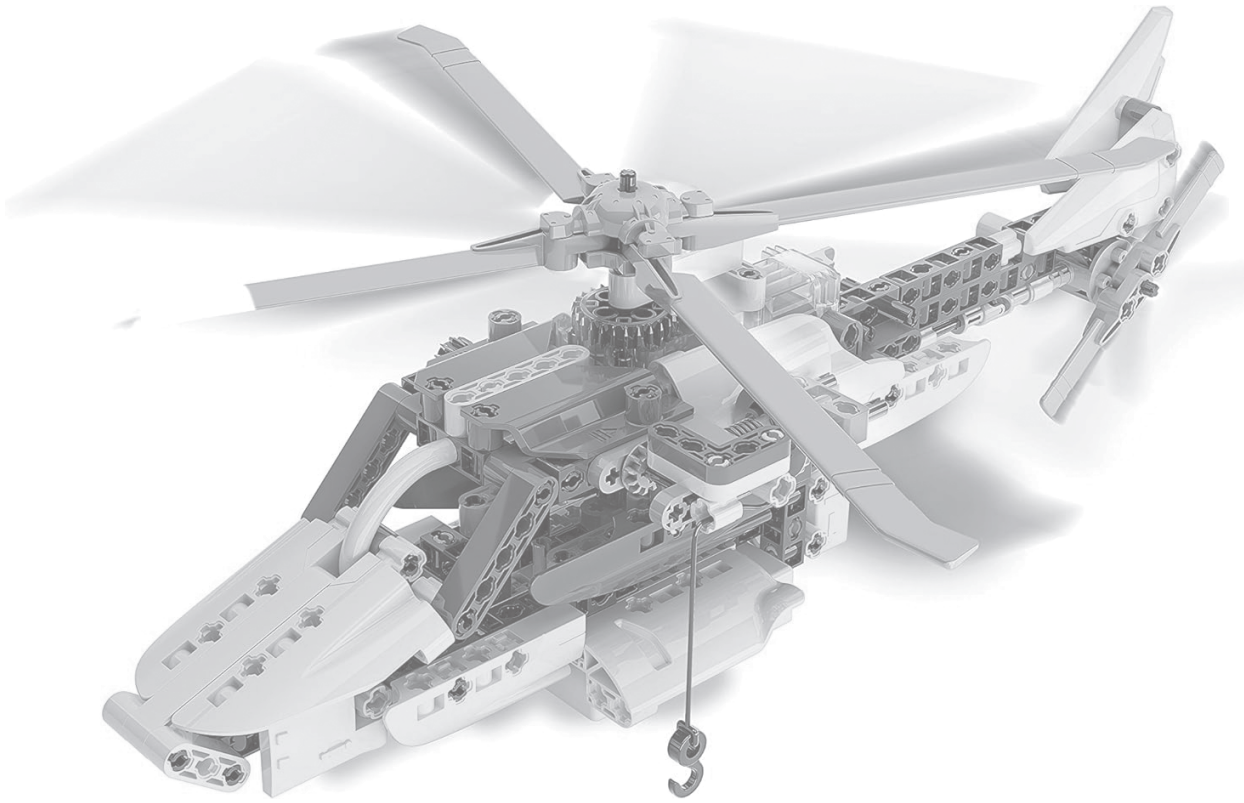

INSTRUCȚIUNI PENTRU ADULTUL CARE SUPRAVEGHEAZĂ ACTIVITATEA: Jucăria este recomandată copiilor cu vârsta mai mare de 8 ani. Un adult trebuie să fie de față pentru a supraveghea procesul de asamblare, precum și manipularea și instalarea componentelor electrice.

ÎNDEPĂRTAREA ȘI INSTALAREA BATERIILOR

Bateriile trebuie instalate și înlocuite numai de către adulți.

Asigurați-vă că dispozitivul este oprit.

- 1 Folosiți o șurubelniță pentru a desface șurubul din capacul compartimentului pentru baterii.
- 2 Îndepărtați bateriile consumate.
- 3 Introduceți 4 baterii AA de 1,5V noi (nu sunt incluse) în compartiment, respectând indicațiile de polaritate din compartiment și de pe baterii.
- 4 Reînșurubați capacul compartimentului pentru baterii.
- 5 Porniți dispozitivul și asigurați-vă că bateriile sunt instalate corect.

Cereți întotdeauna ajutorul unui adult pentru a instala bateriile!



Alimentare: 6V d.c.

Baterii: 4 x 1,5V AA

Bateriile nu sunt incluse.

ALTE RECOMANDĂRI:

- Bateriile pot fi periculoase dacă sunt înghițite; țineți-le departe de accesul copiilor.
- Îndepărtați bateriile dacă produsul nu va fi folosit pentru mult timp.
- Nu încercați să desfaceți bateriile.
- Nu aruncați bateriile în foc.

FOLOSIREA ÎN SIGURANȚĂ A BATERIILOR/ACUMULATORILOR

ATENȚIE!

- Instalați întotdeauna bateriile în pozițiile indicate de simbolurile de polaritate + și -.
- Îndepărtați bateriile consumate din produs.
- Nu scurtcircuitați bornele de alimentare.
- Nu atingeți contactele din compartimentul pentru baterii, deoarece acest lucru poate provoca un scurtcircuit.
- Scoateți acumulatorii din produs înainte de a-i încărca. A se încărca numai sub supravegherea unui adult.
- Nu încercați să încărcați baterii nereîncărcabile.
- Nu folosiți în același timp baterii vechi și noi sau baterii de tipuri diferite (standard, alcaline sau reîncărcabile).
- Protejați mediul înconjurător! Duceți produsele electrice și electronice și bateriile de care nu mai aveți nevoie la un centru de colectare corespunzător. Nu le aruncați împreună cu deșeurile menajere.

LISTA COMPONENTELOR

	X 2		X 2		X 1		X 1
	X 2		X 4		X 1		X 1
	X 2		X 1		X 1		X 1
	X 4		X 1		X 1		X 1
	X 4		X 2		X 5		X 1
	X 4		X 1		X 2		X 1
	X 4		X 1		X 1		X 1
	X 4		X 1		X 1		X 1
	X 4		X 10		X 2		X 1
	X 4		X 2		X 5		X 1
	X 4		X 32		X 1		X 1
	X 2		X 8		X 1		X 1
	X 2		X 8		X 2		X 1
	X 2		X 32		X 3		X 1
	X 2		X 16		X 3		X 1
	X 1		X 12		X 1		X 1
	X 1		X 20		X 1		X 1
	X 1		X 1		X 1		X 1
							X 1
							X 4
							X 4

FOLOSIREA INSTRUMENTULUI DE EXTRACȚIE

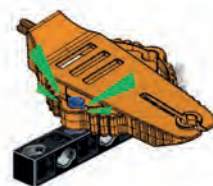
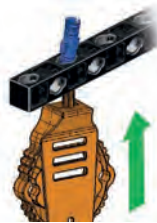
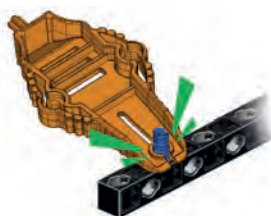

N.B.: cereți unui adult să îndepărteze piesele din suporturile de plastic. Orice resturi ascuțite trebuie aruncate imediat.

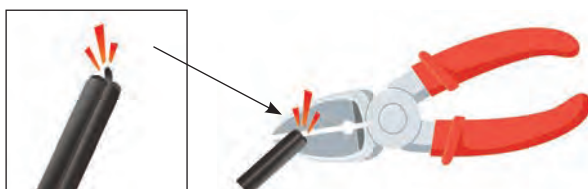

FORȚA DE PORTANȚĂ

Forța de portanță: este forța care se opune gravitației, permițând avionului sau elicopterului să zboare. Datorită formei aripii, aerul se mișcă cu viteze diferite pe cele două suprafețe ale aripii. Alunecă mai lent pe partea inferioară a aripii și mai rapid pe partea superioară. Fluxul mai lent de aer exercită o presiune mai mare, împingând aripa în sus.

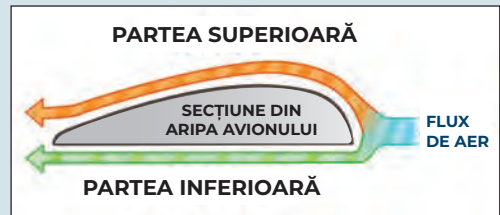

ZBORUL CU ELICOPTERUL

Forța care permite elicopterului să zboare se numește portanță și este generată de o aripă rotativă numită rotor. Rotorul este compus dintr-un ax rotativ pe care sunt atașate două sau mai multe elice.

ROTORUL PRINCIPAL ȘI ROTORUL ANTICUPLU

Rotorul principal permite elicopterului să se ridice în zbor. Al doilea rotor, numit **rotorul anticuplu**, este necesar pentru a menține elicopterul drept. În timpul zborului, **a treia lege a lui Newton** intră în acțiune: Când un corp acționează asupra altui corp cu o forță (numită forță de acțiune), cel de-al doilea corp acționează și el asupra primului cu o forță (numită forță de reacțiune) de aceeași mărime și de aceeași direcție, dar de sens contrar. Astfel că rotația elicelor produc o reacțiune în fuselaj, făcându-l să se rotească în direcția opusă. **Rotorul anticuplu** produce o forță care se **opune** și forța ce acționează asupra fuselajului. Fără acest al doilea rotor, elicopterul s-ar roti incontrolabil.

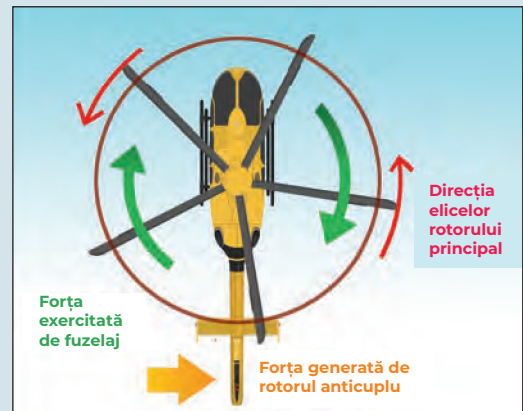

DISCUL FULANT

O piesă esențială de echipament pentru pilotul de elicopter este discul fulant. Montat în jurul axului rotativ, este conectat la elice și se mișcă liber în sus sau în jos pentru a genera portanță.

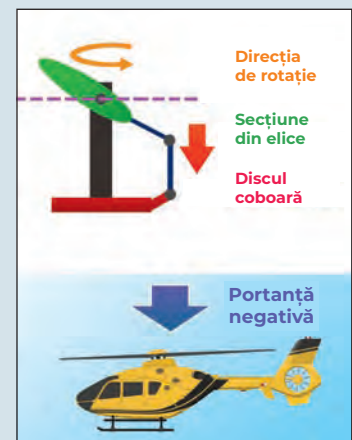
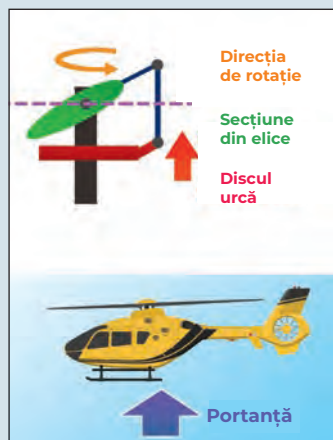
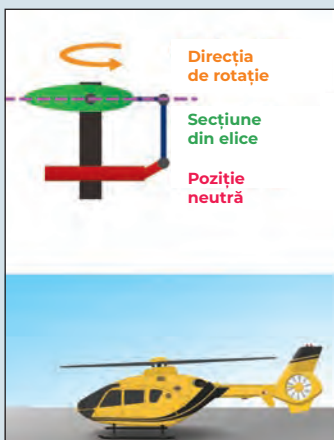

Pilotul poate de asemenea să încline discul fulant, rezultând în înclinarea discului rotor. Astfel se creează două zone diferite de portanță, ducând la o portanță scăzută.

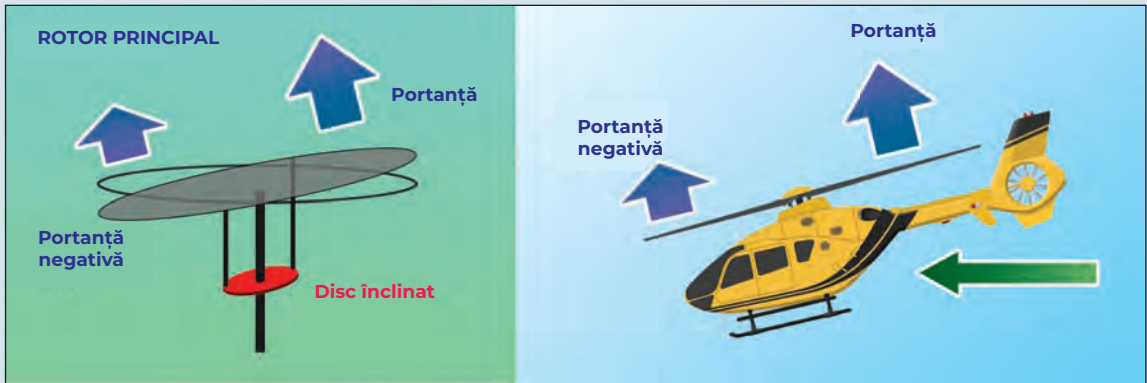

PILOTAREA UNUI ELICOPTER

Pilotarea elicopterului necesită o coordonare excelentă deoarece pilotul trebuie să opereze trei mecanisme simultan: **maneta de control colectiv** pentru zborul vertical, **maneta de comandă ciclică** pentru mișcare orizontală, **pedalele** pentru a schimba direcția.

COMANDA CICLICĂ

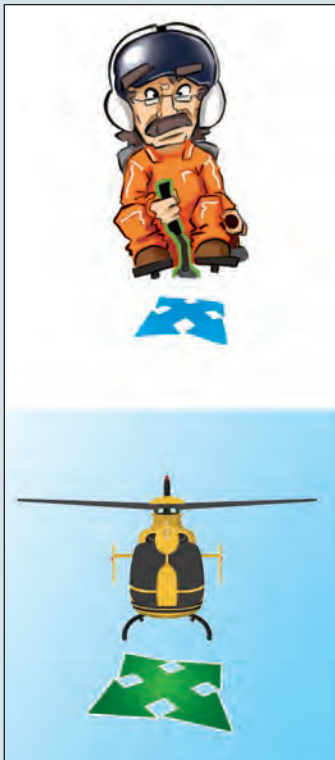

Pilotul operează maneta de comandă ciclică, iar elicopterul se mișcă la stânga sau la dreapta, înainte sau înapoi.

CONTROLUL COLECTIV



Pilotul operează maneta de control colectiv, iar elicopterul scade sau urcă în altitudine.

PEDALELE

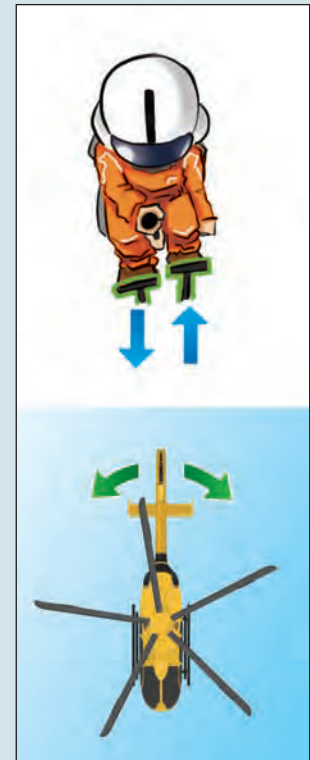

Pilotul operează pedalele, iar elicopterul își schimbă direcția.

ECLIOPTERUL DE SALVARE MONTANĂ



Urmați instrucțiunile interactive 3D din aplicație.

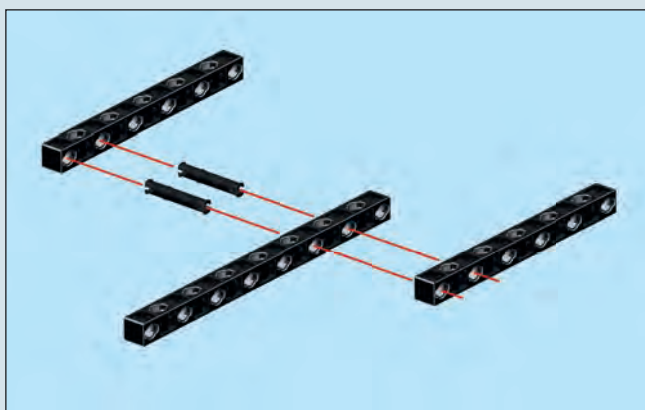

1

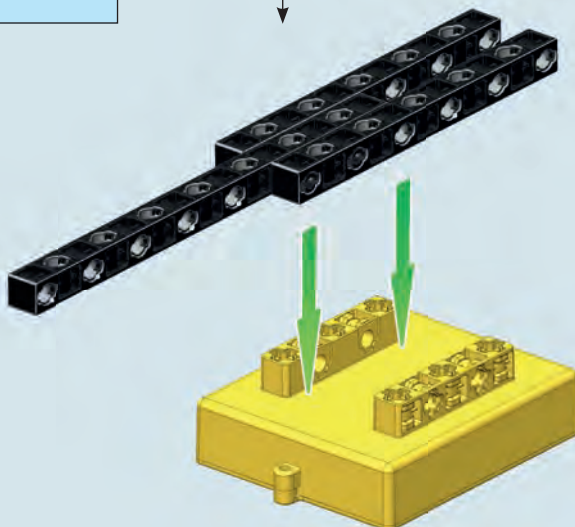
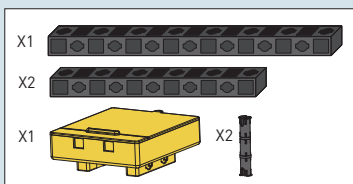

2

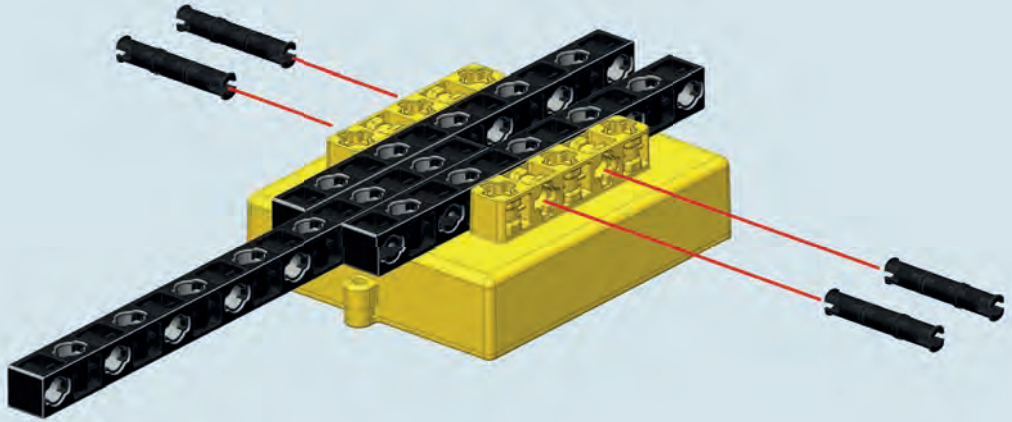

3

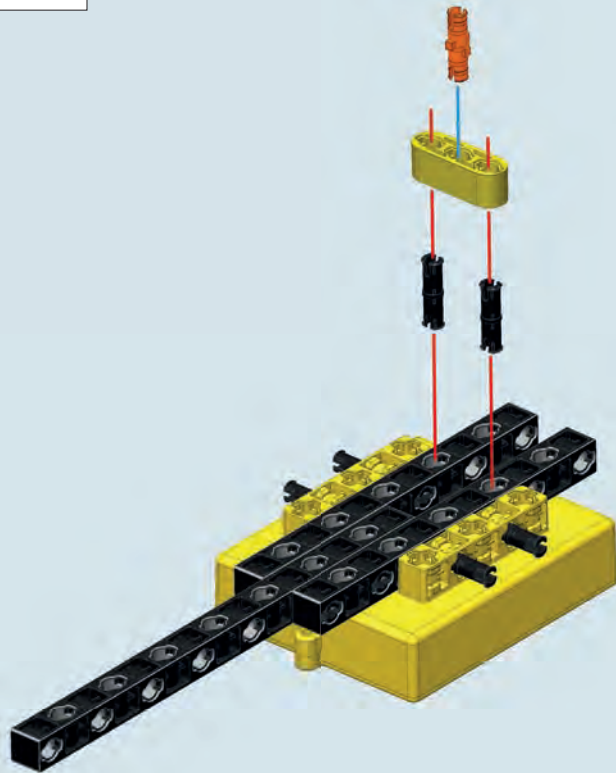

4

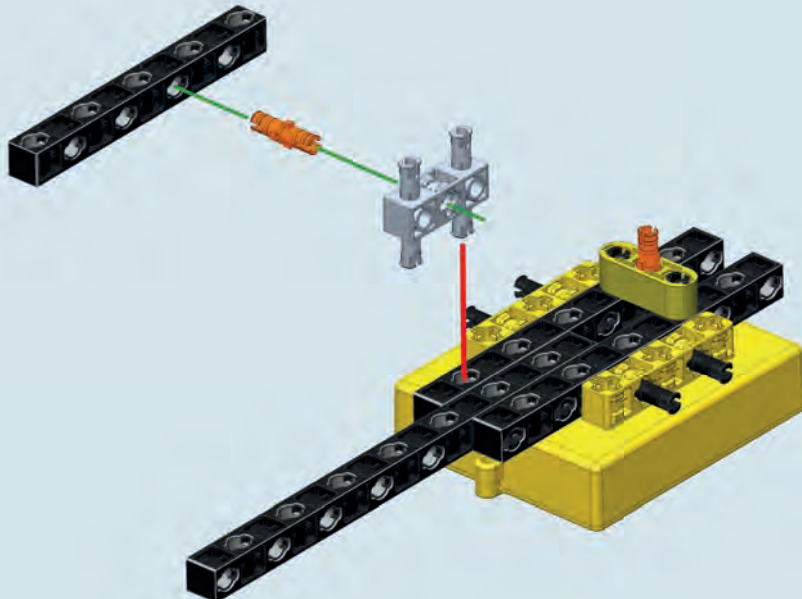

5

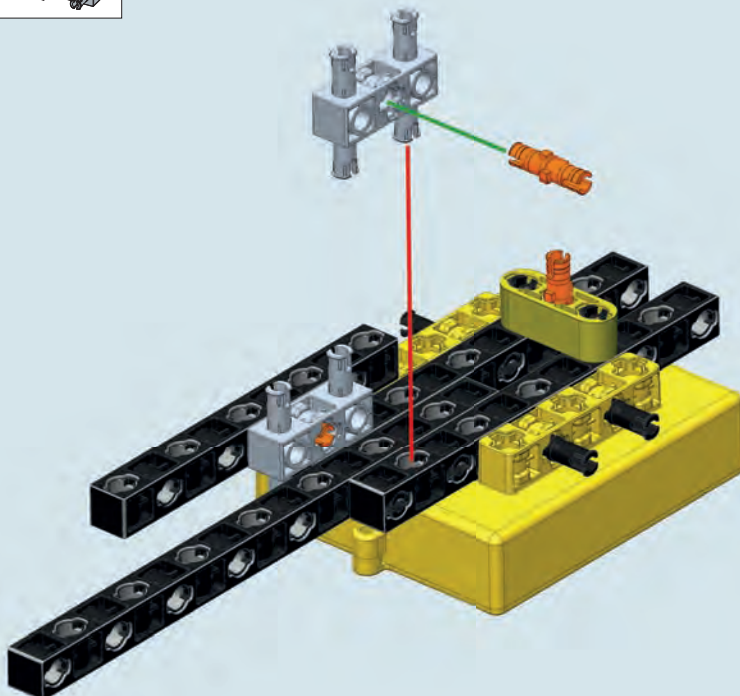

6

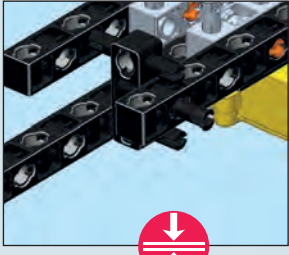
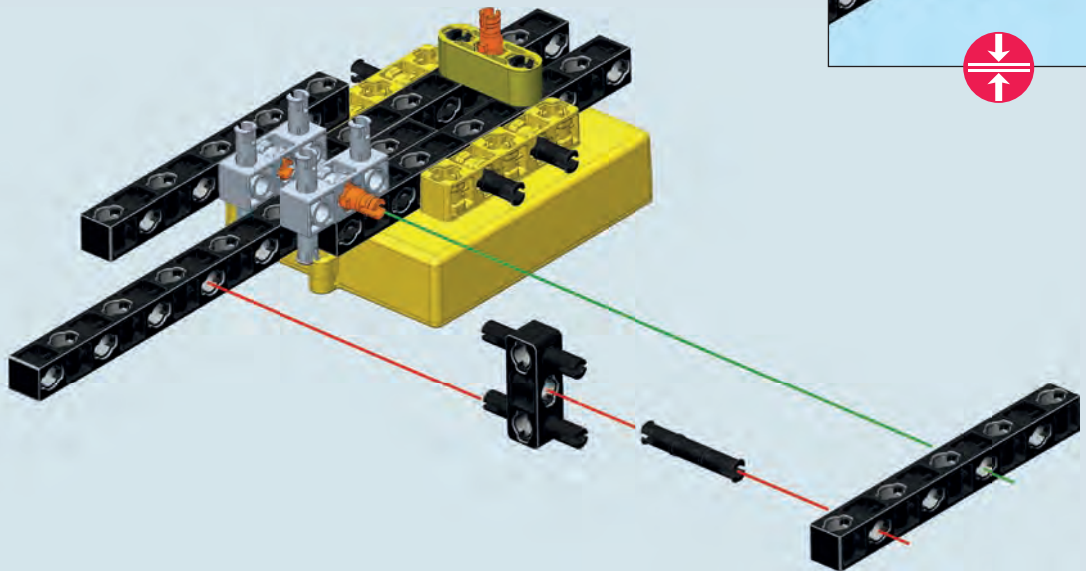
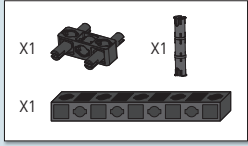

7

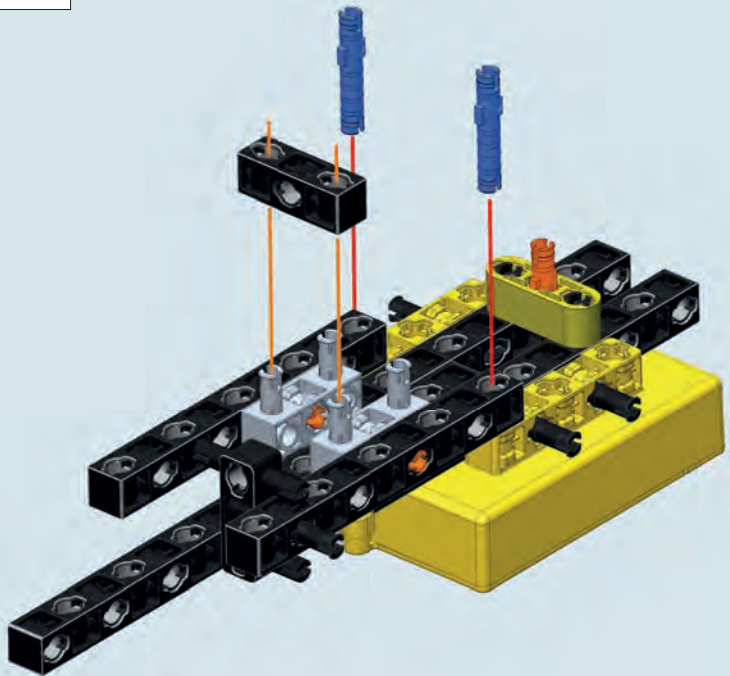
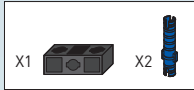

8

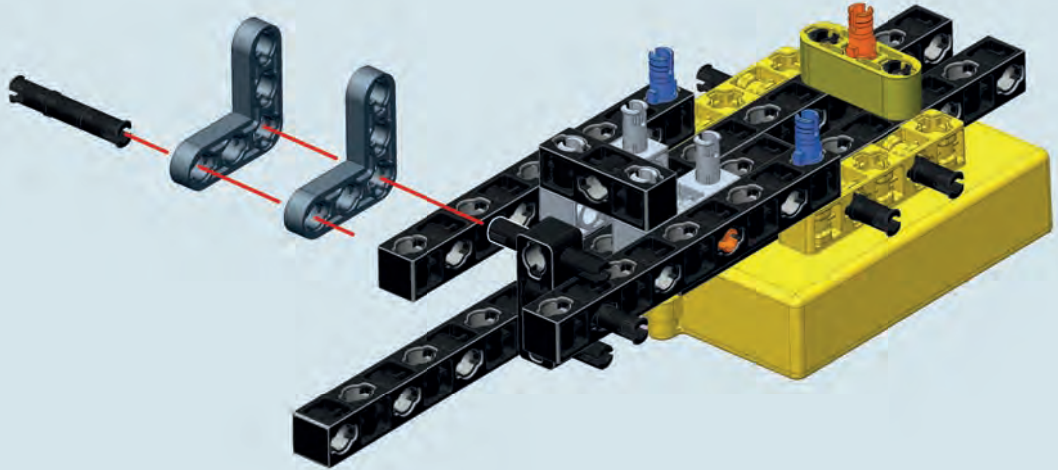

9

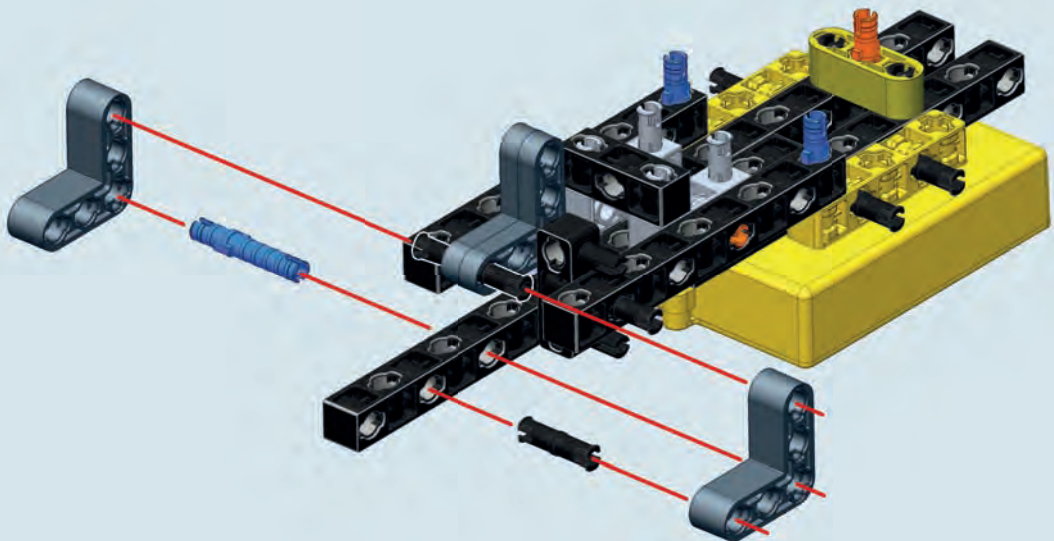
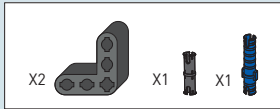

10

- X1
- X1
- X2
- X2

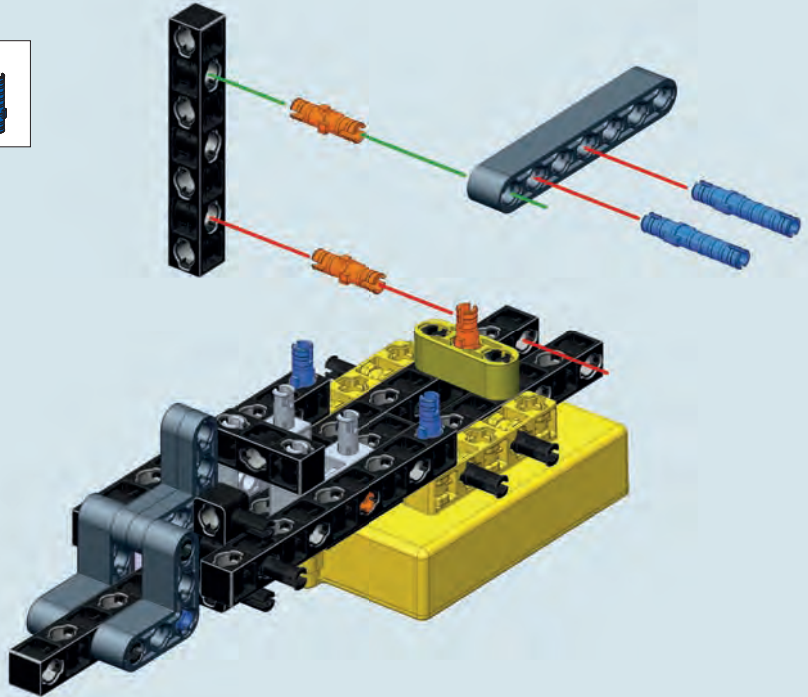

11

- X1
- X1

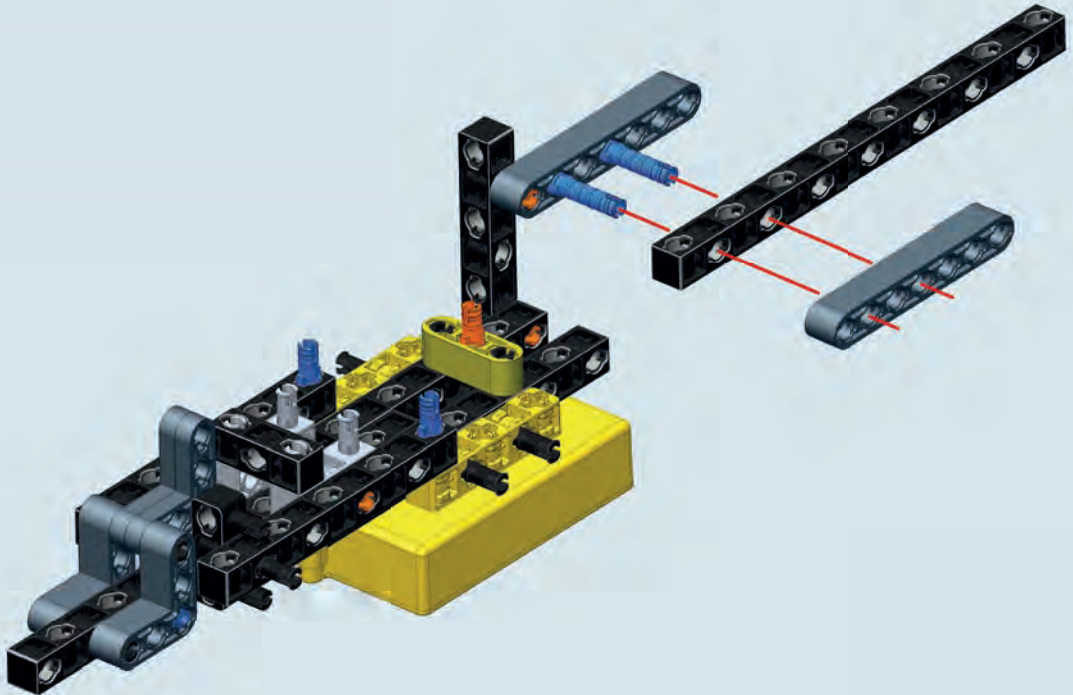

12

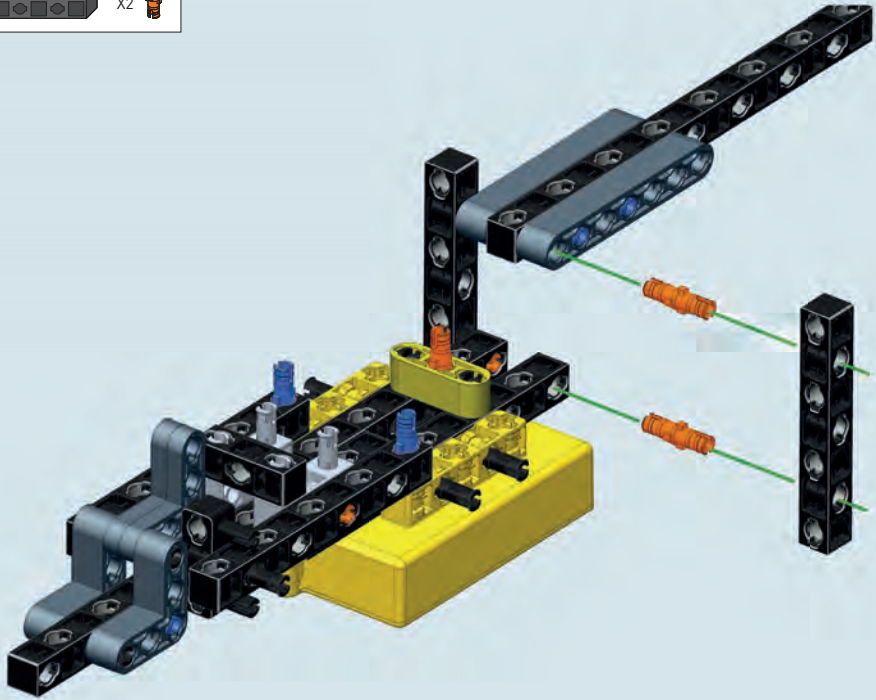

13

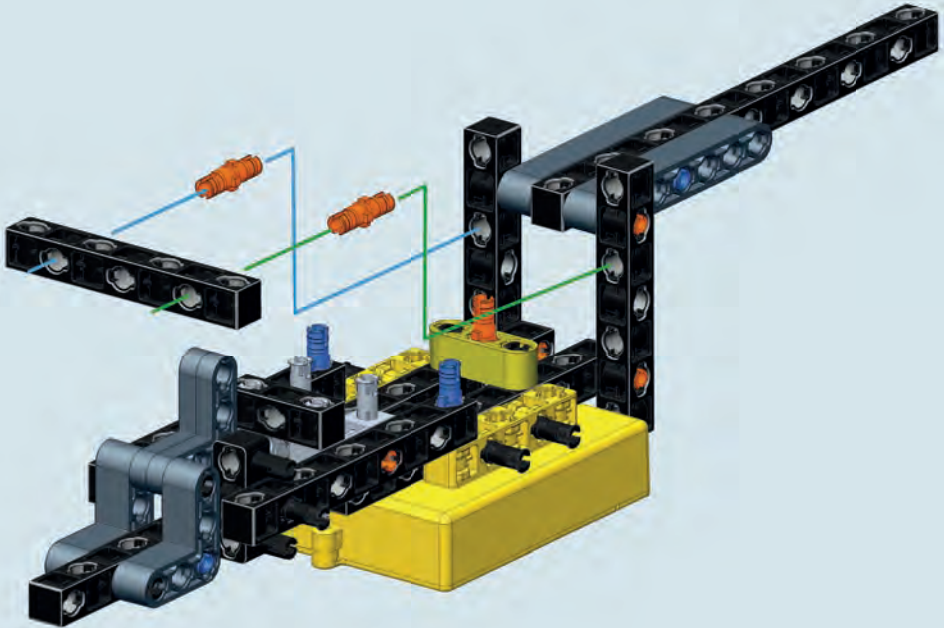

14

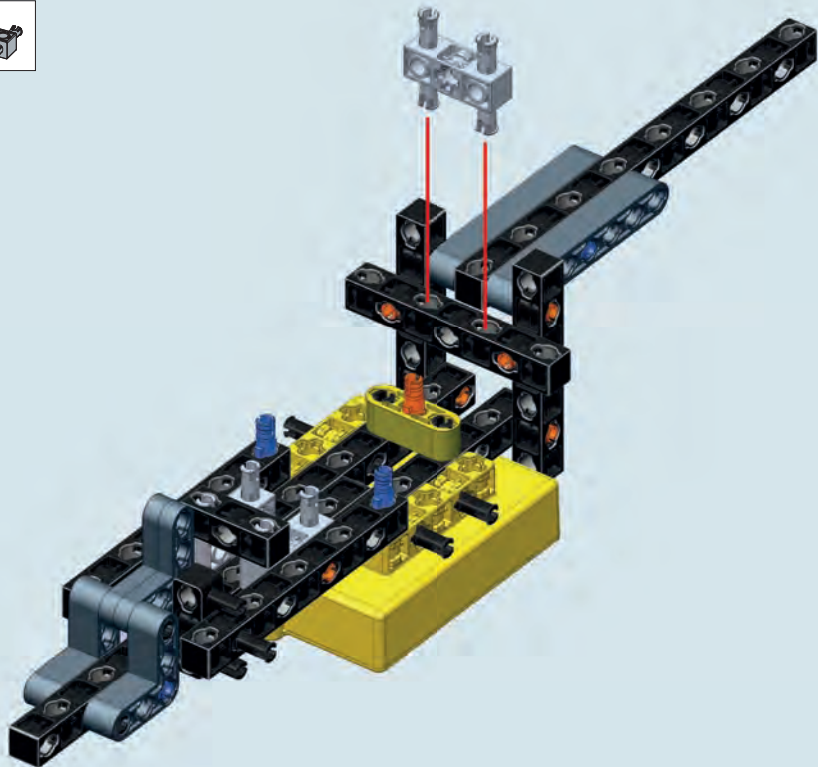

15

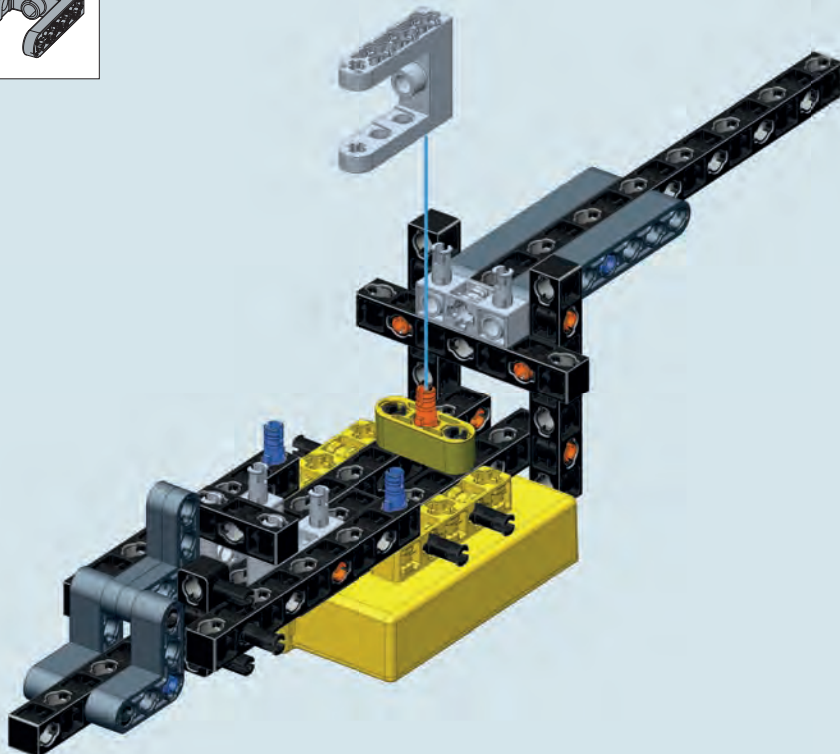
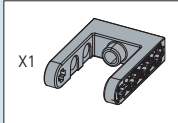

16

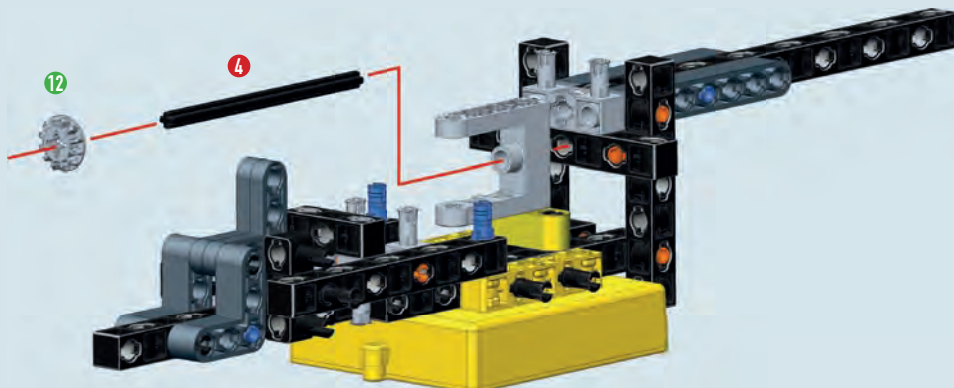

17

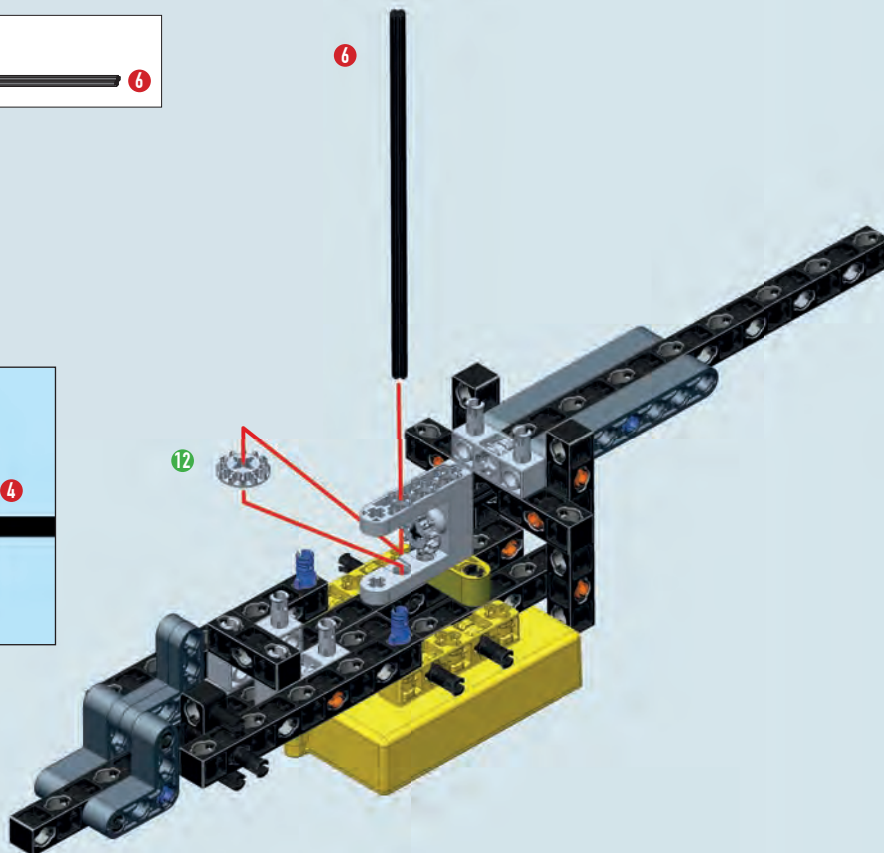
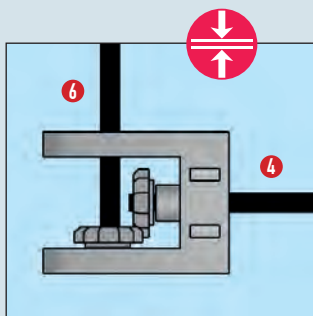
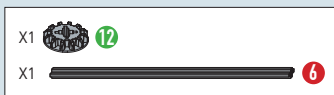

18

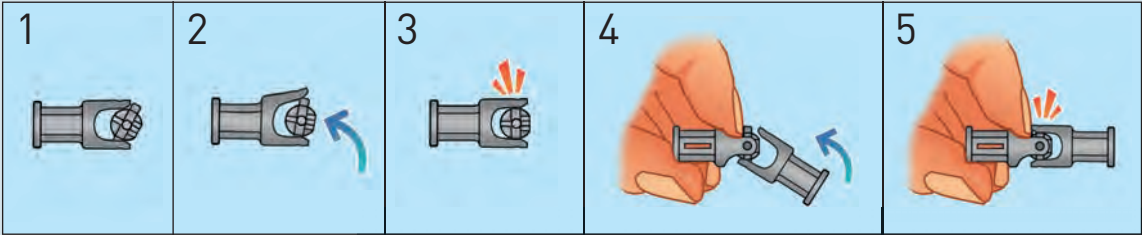
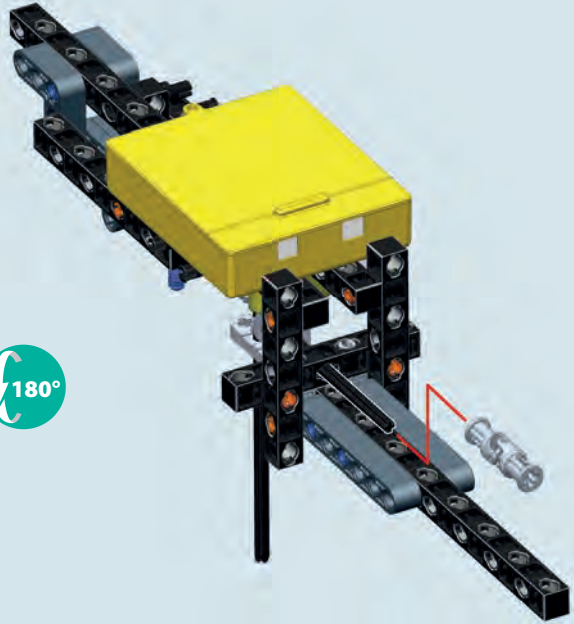

19

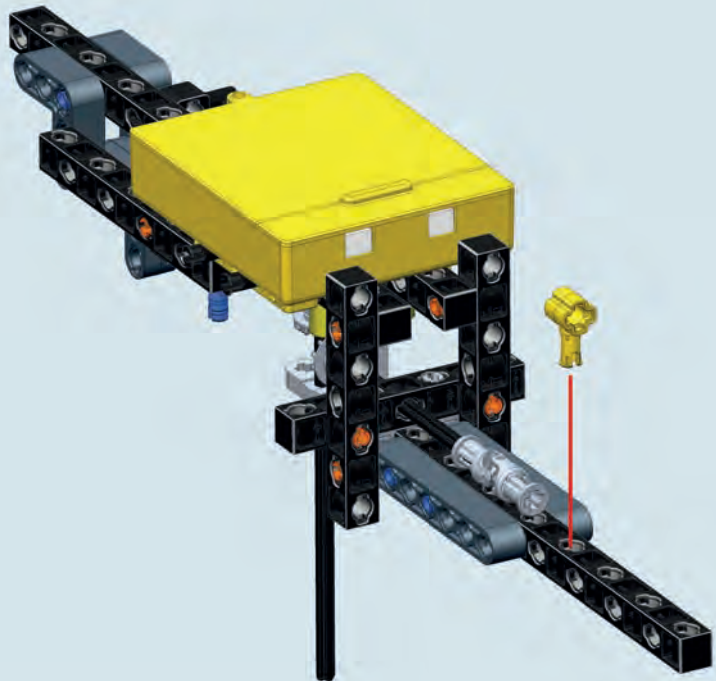

20

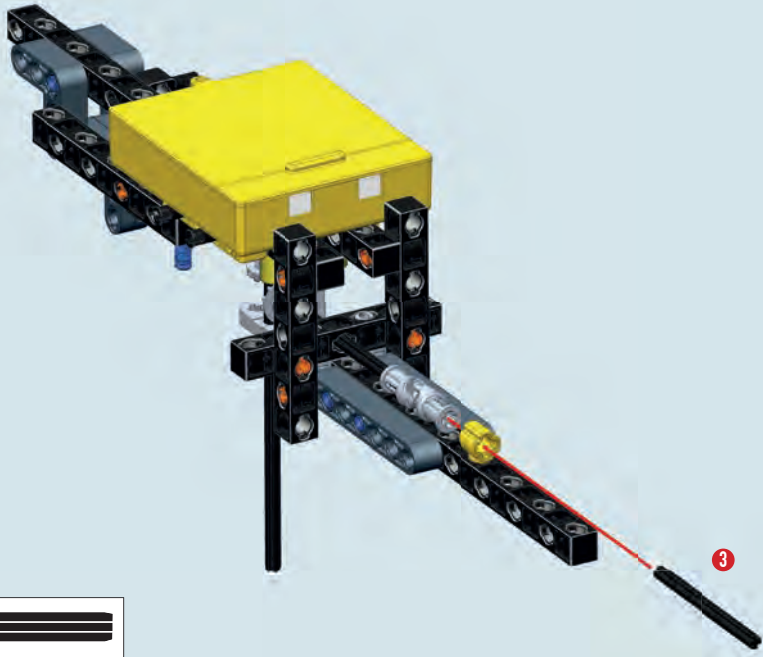

21

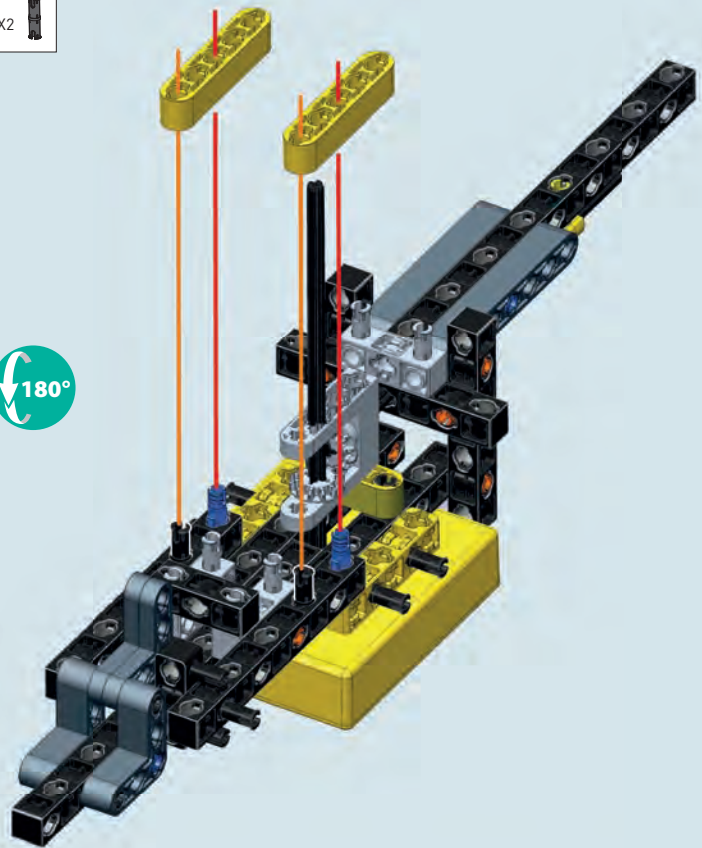
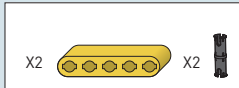

22

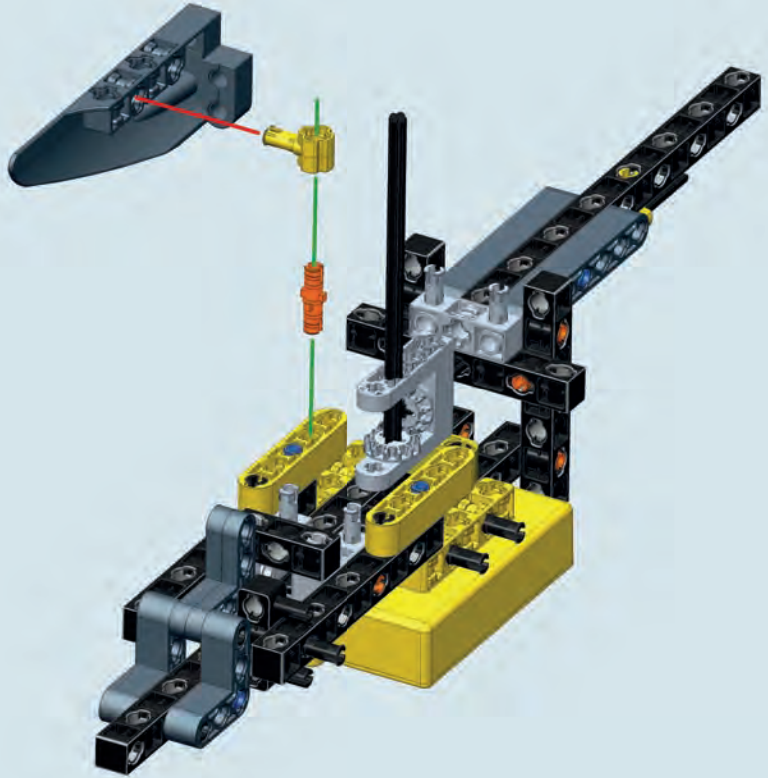
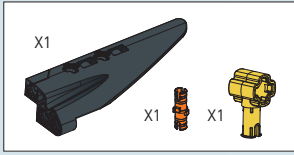

23

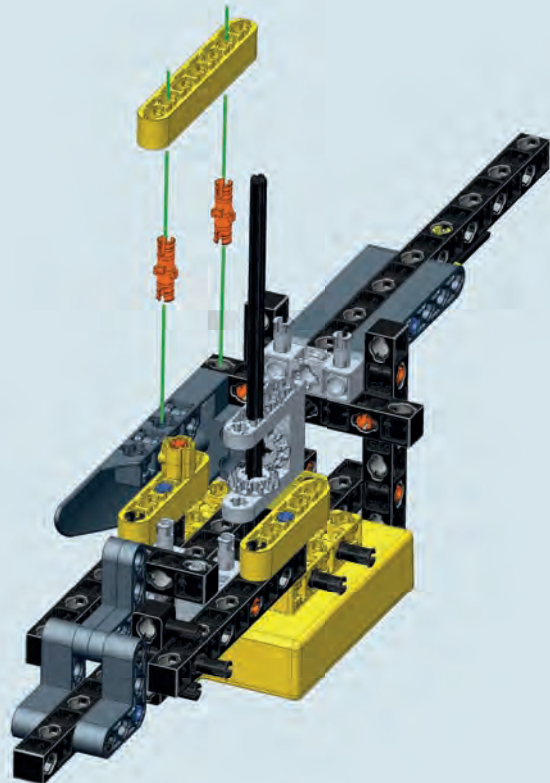

24

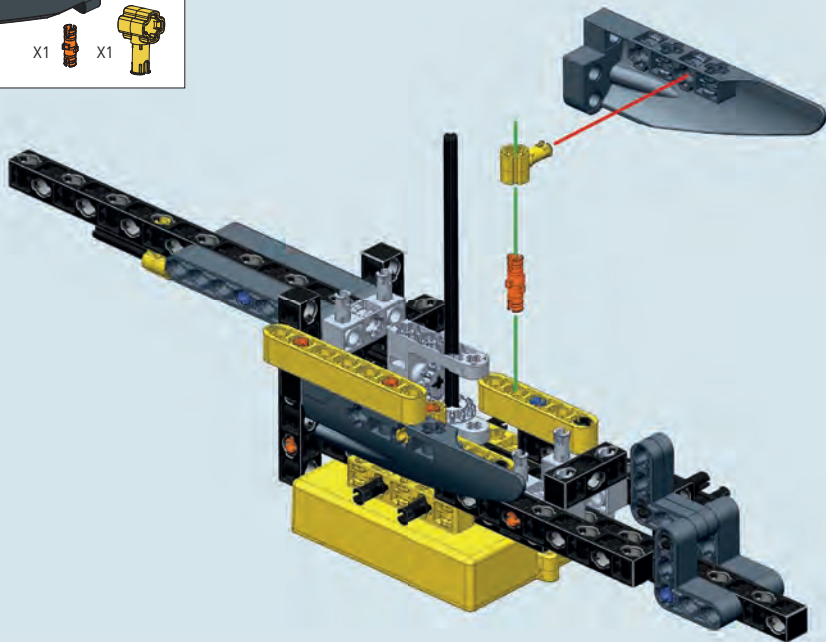
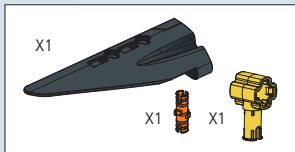

25

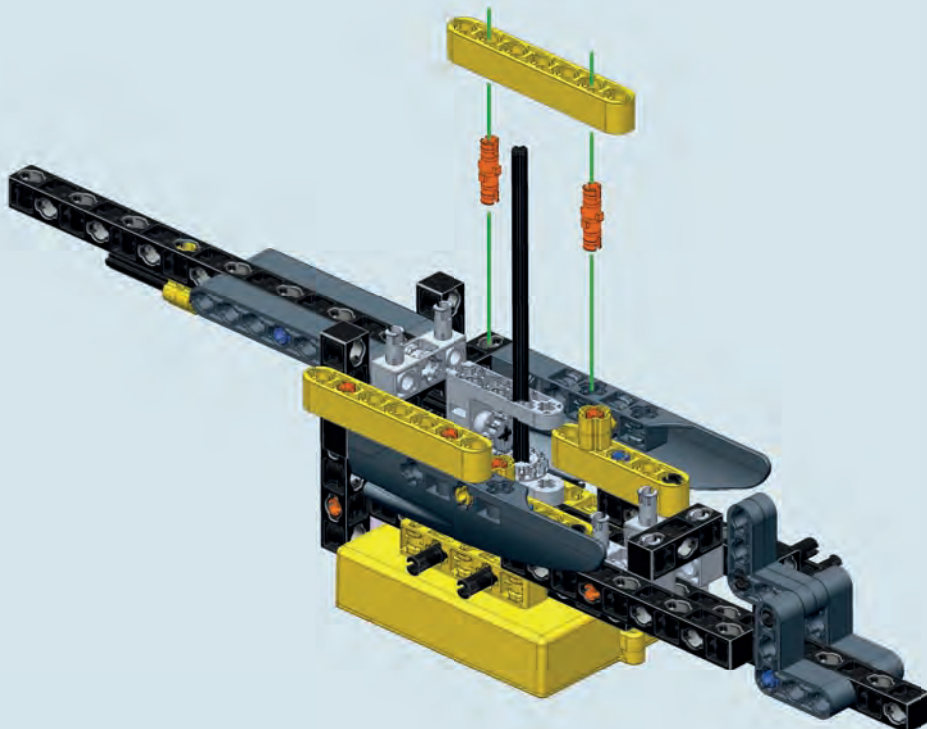
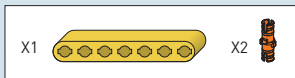

26

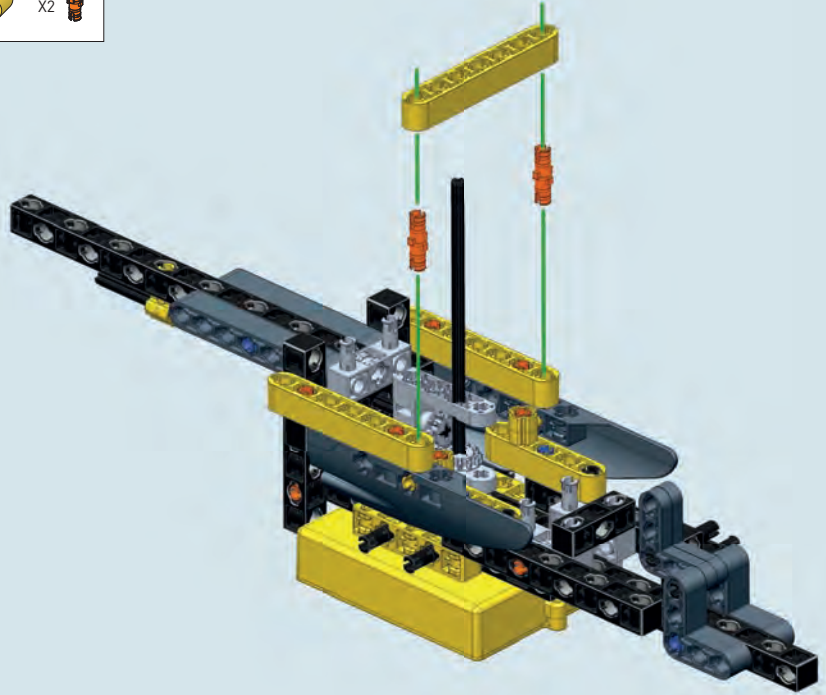
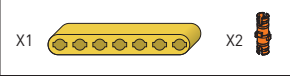

27

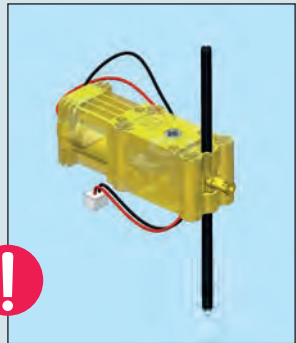
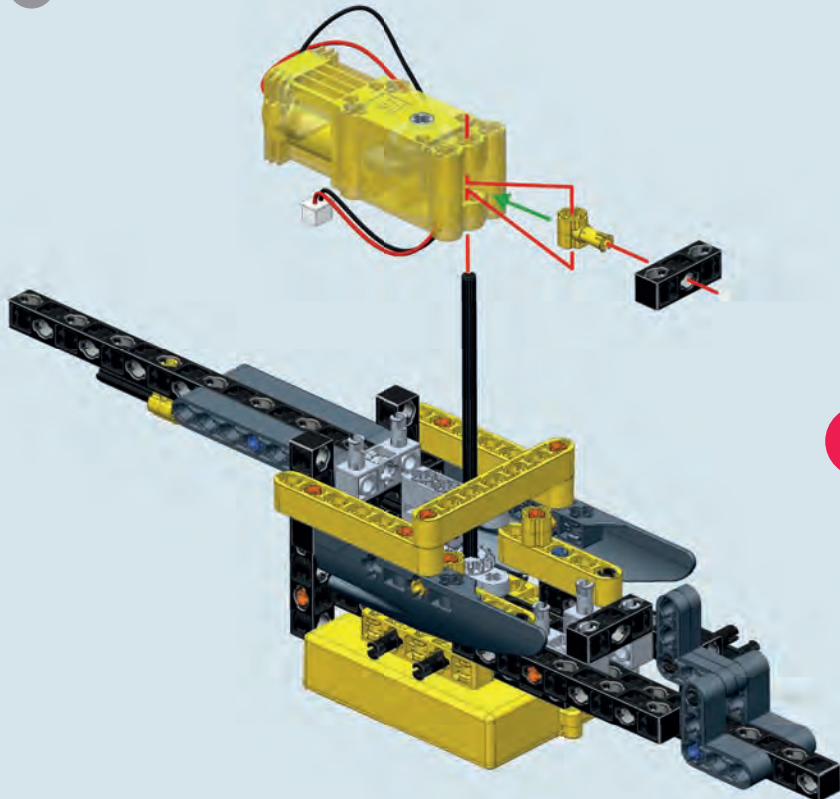
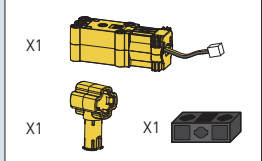

28

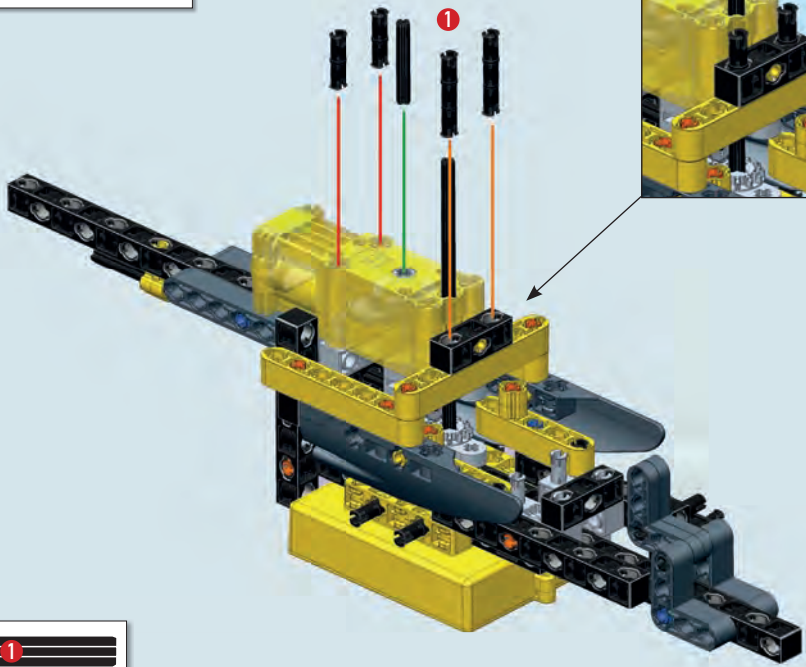
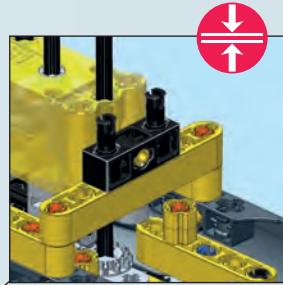

29

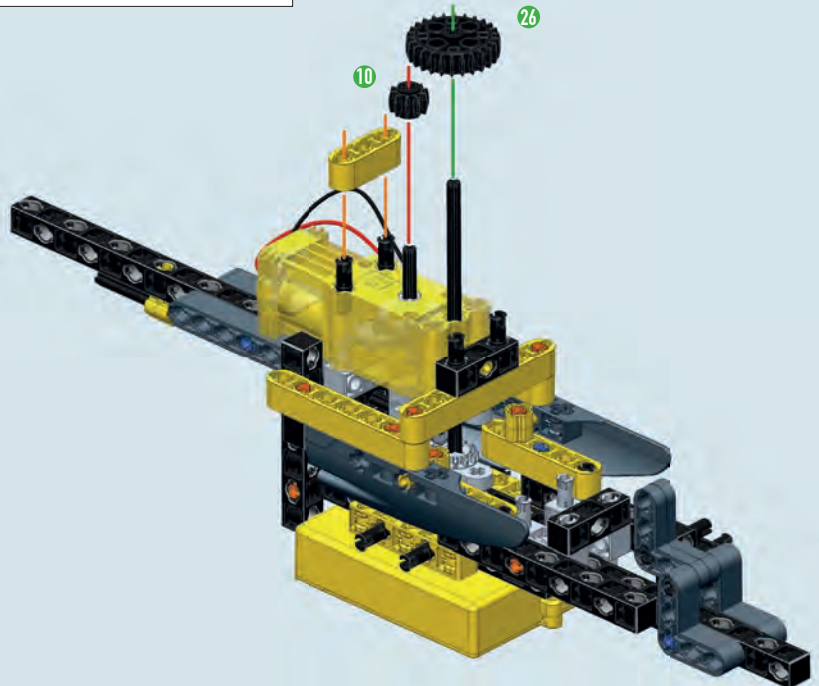
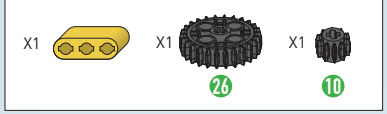

30

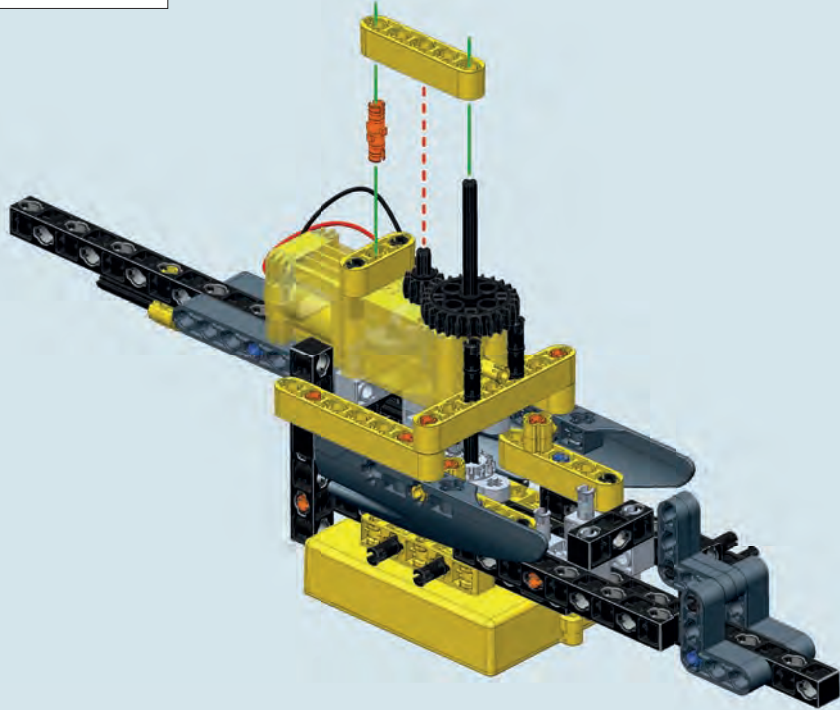
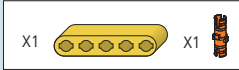

31

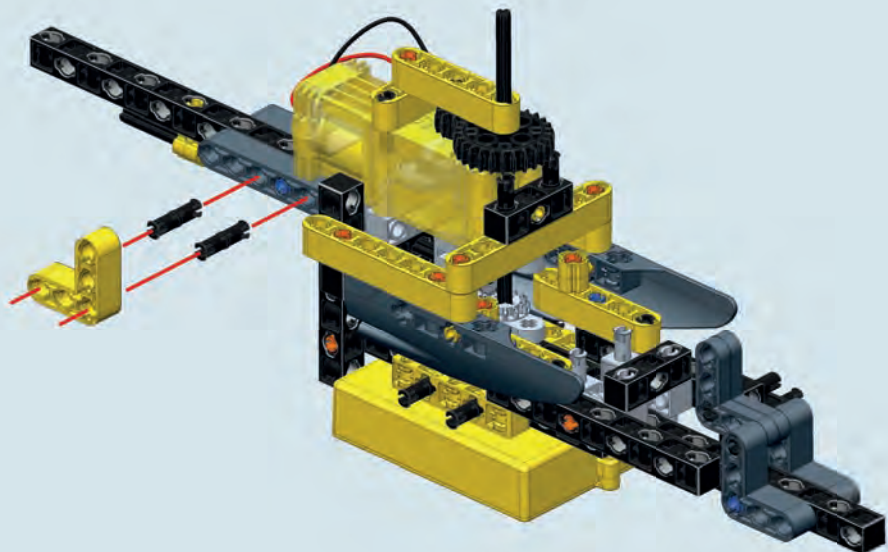
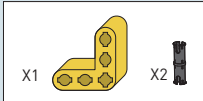

32

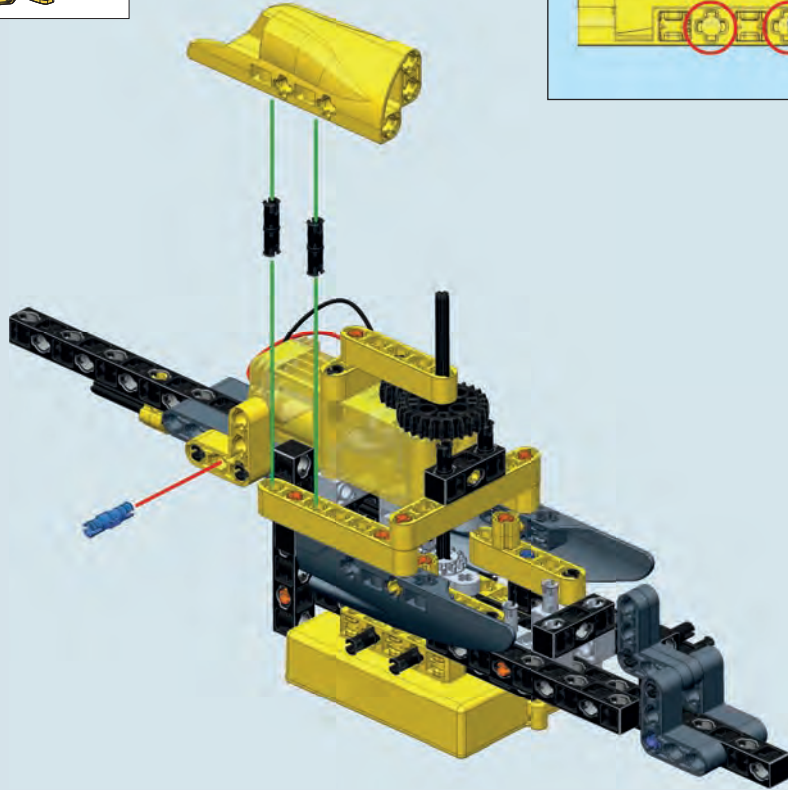
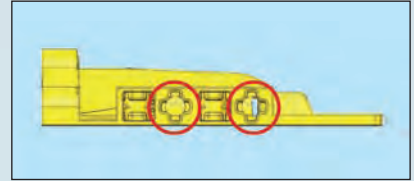
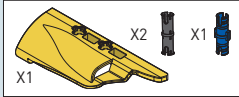

33

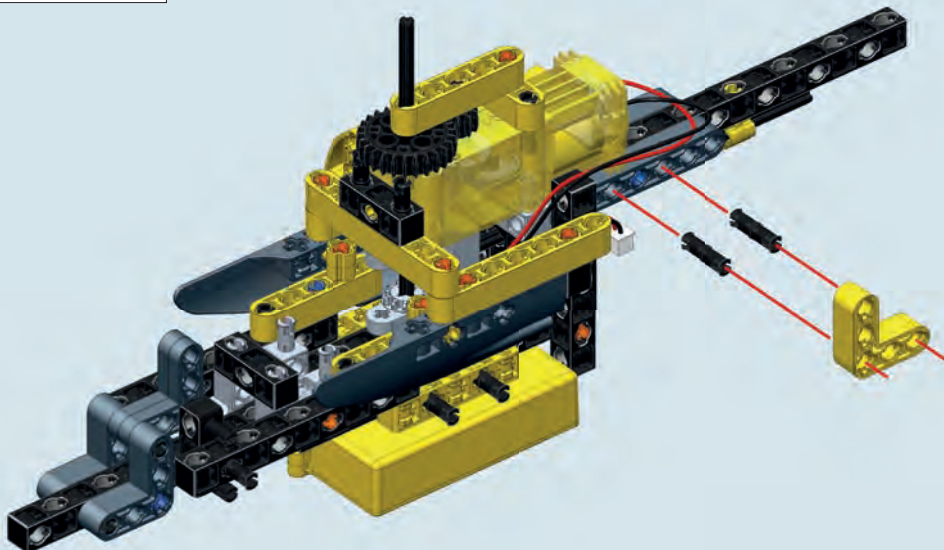
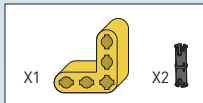

34

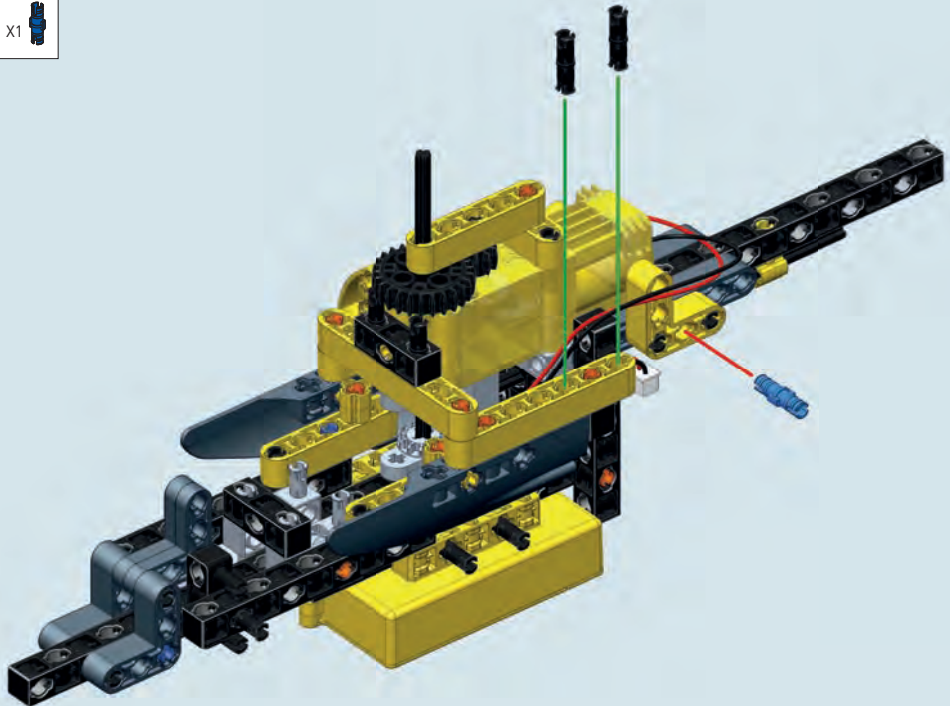
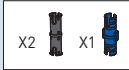

35

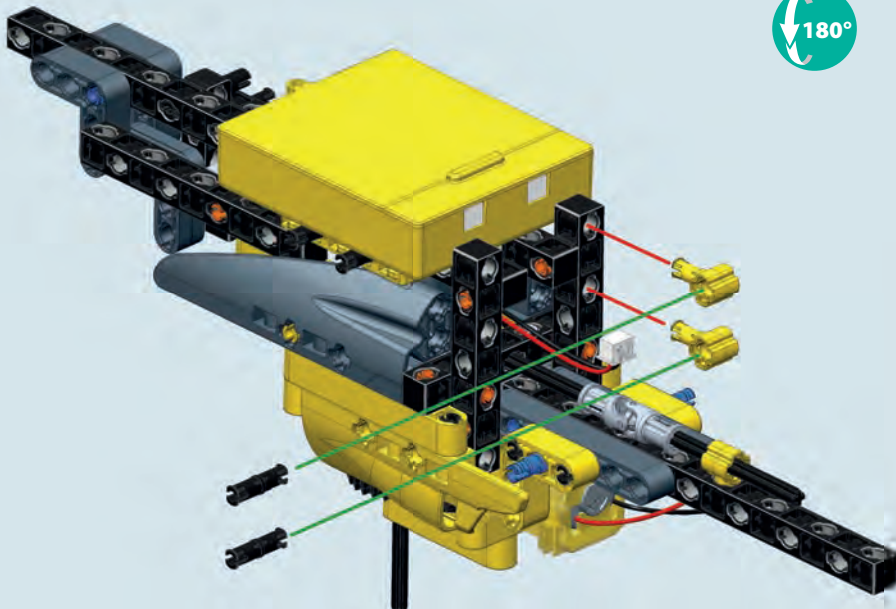
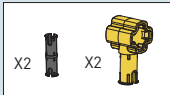

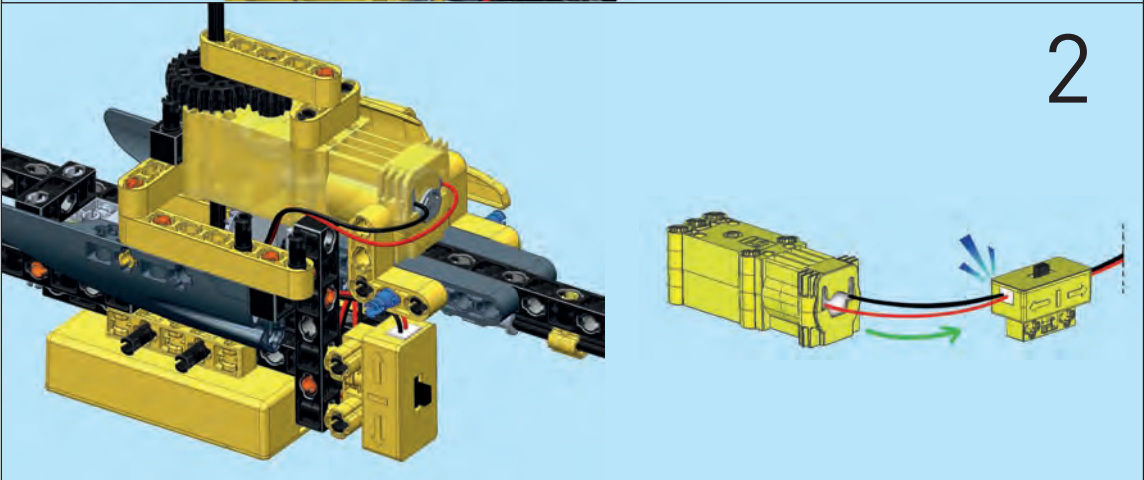
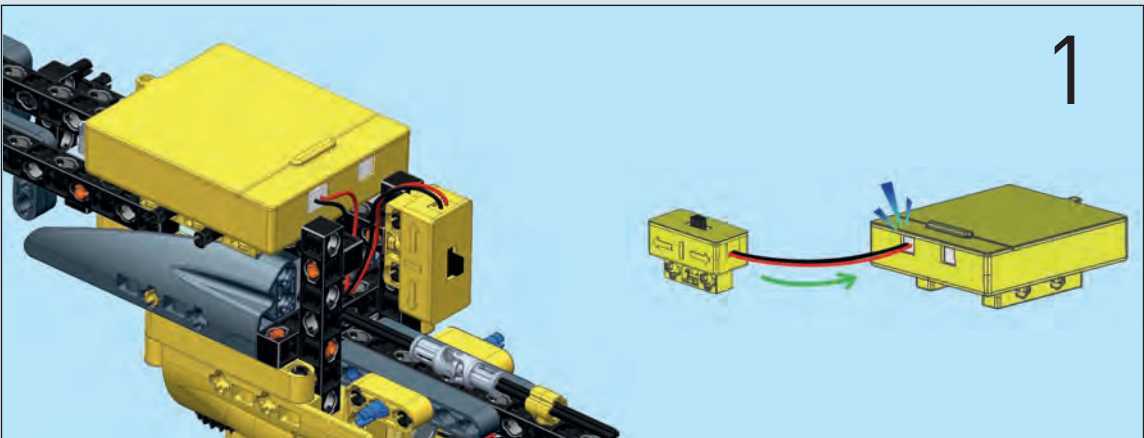
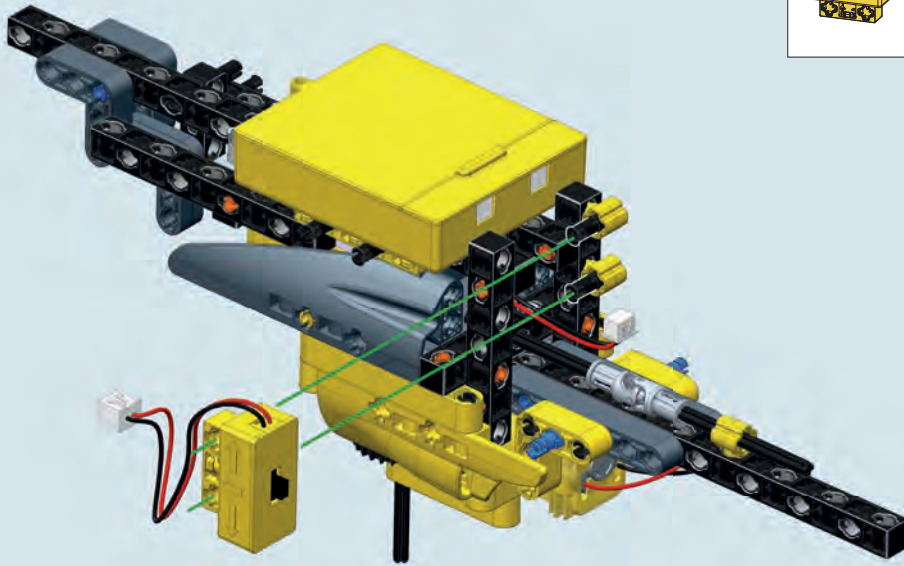
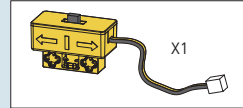

37

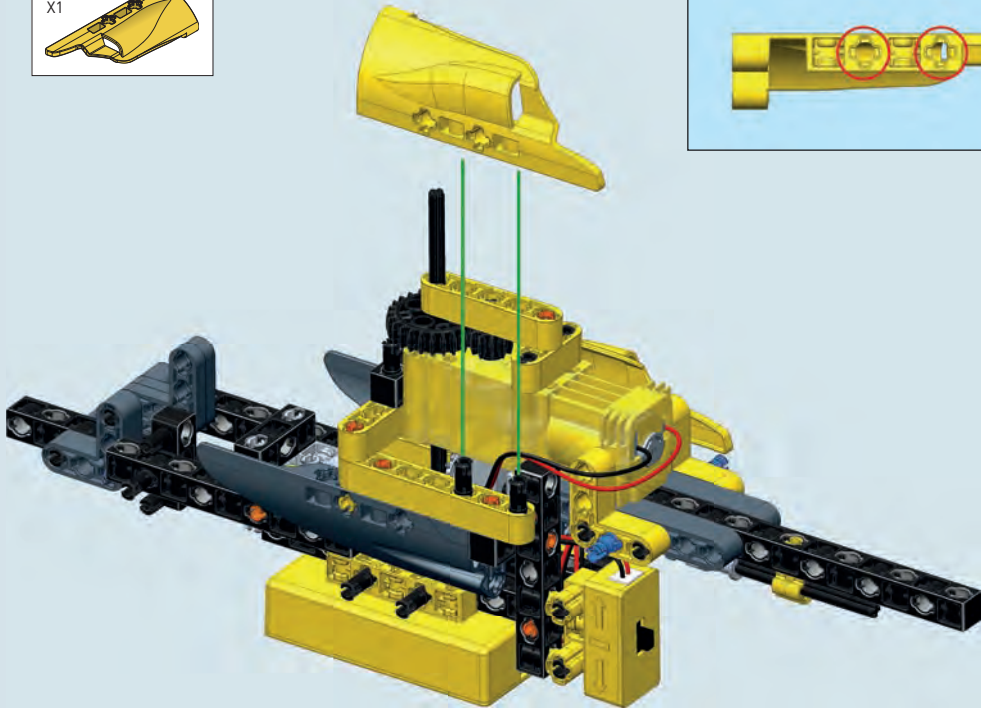
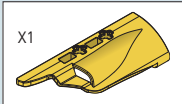

38

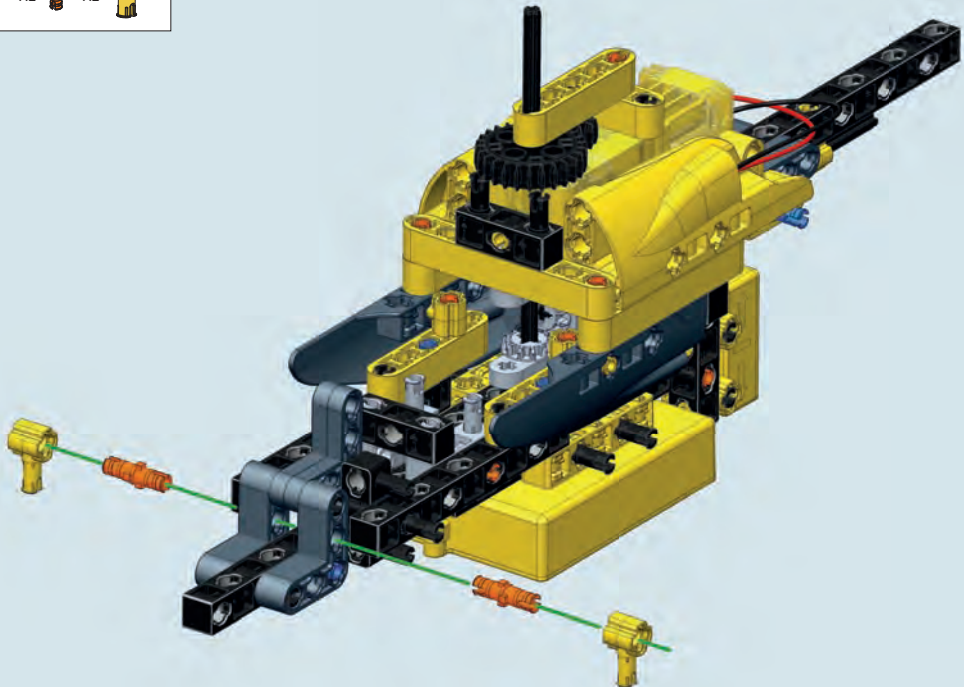
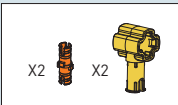

39

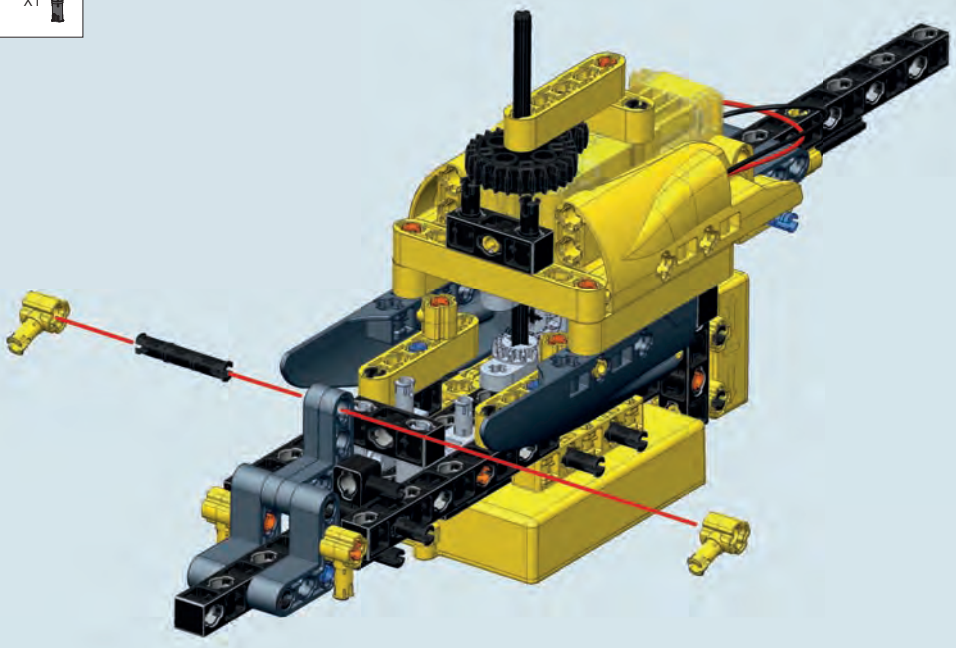

40

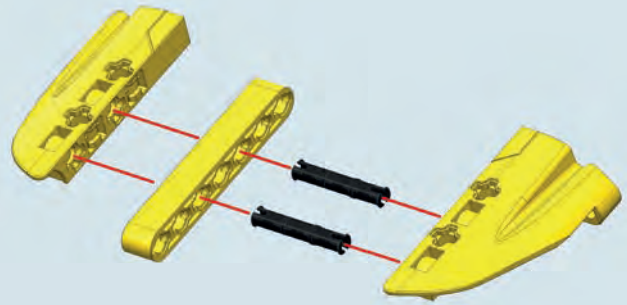
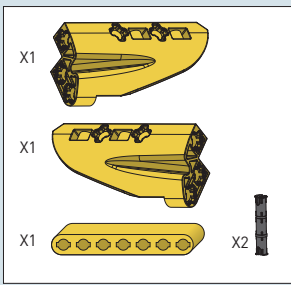

41

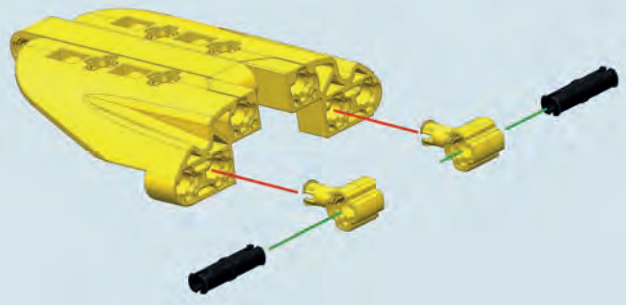
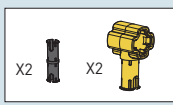

42

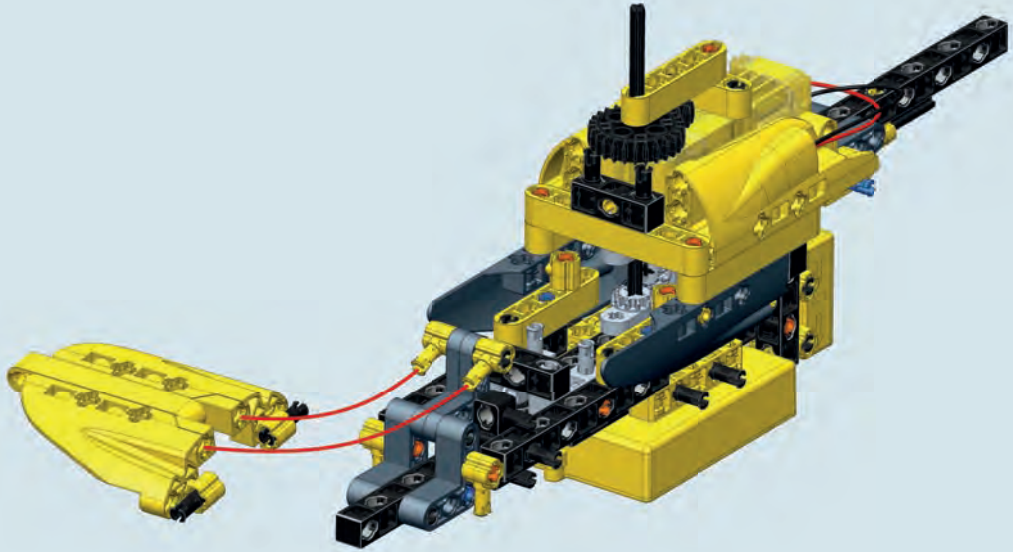

43

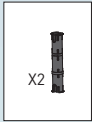

44

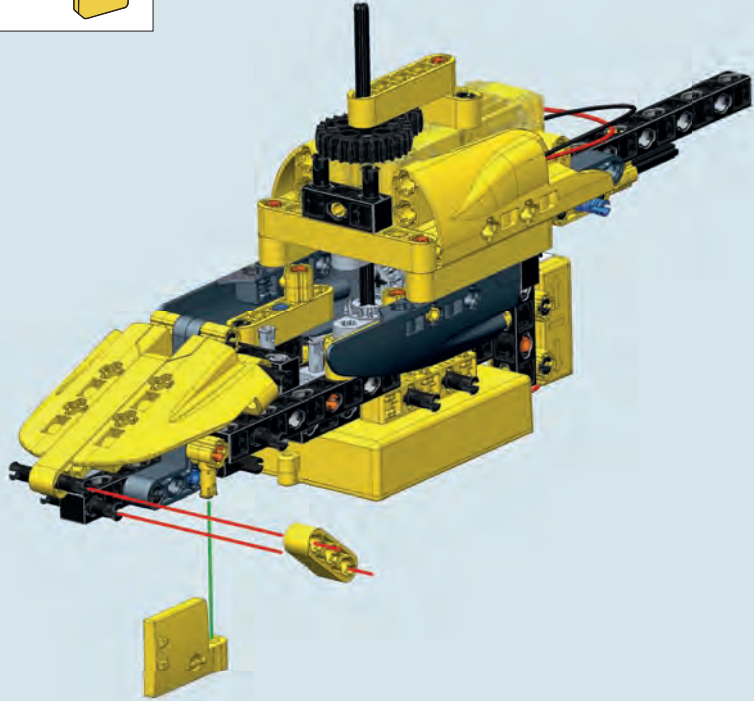
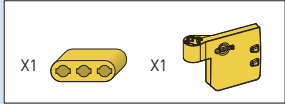

45

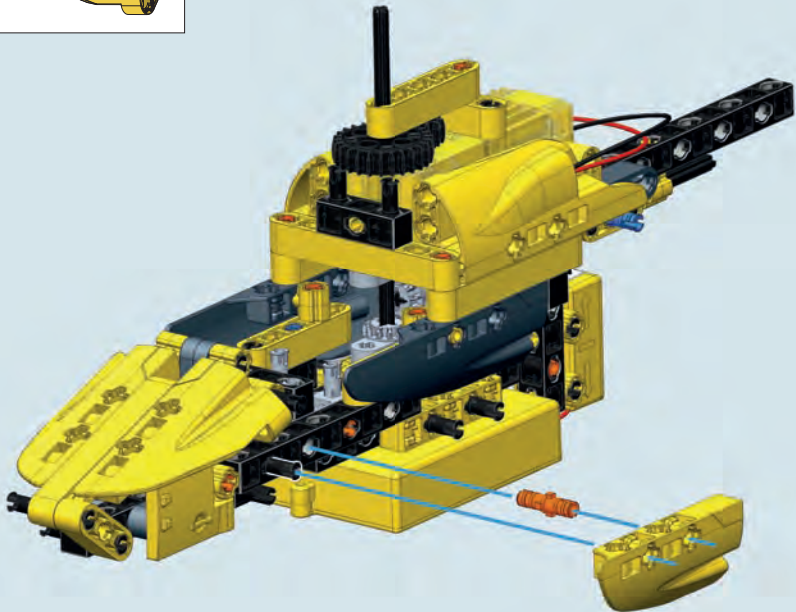
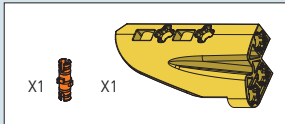

46

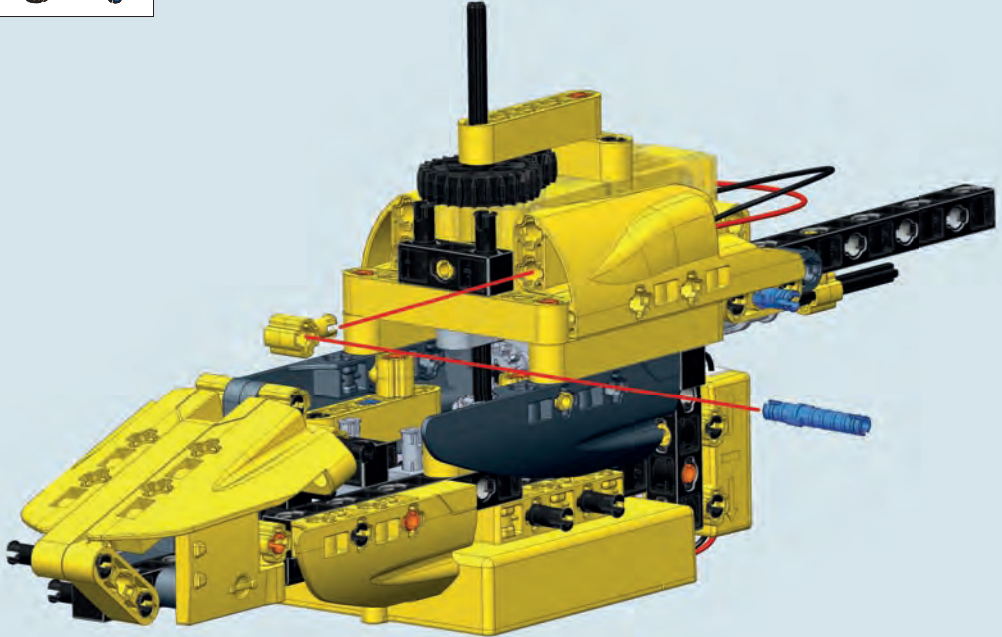

47

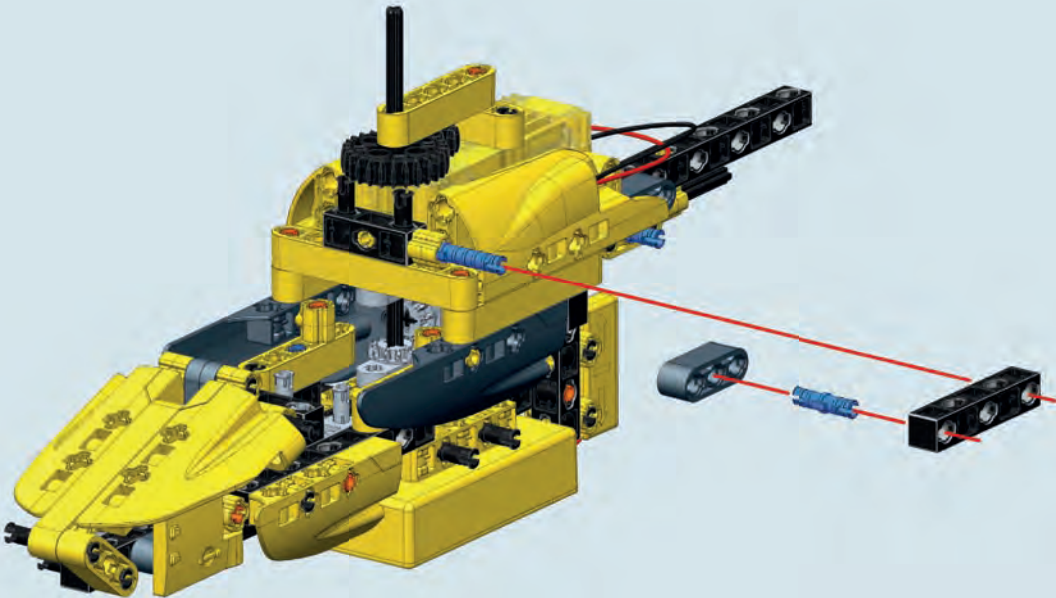
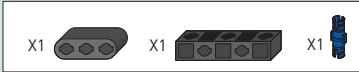

48

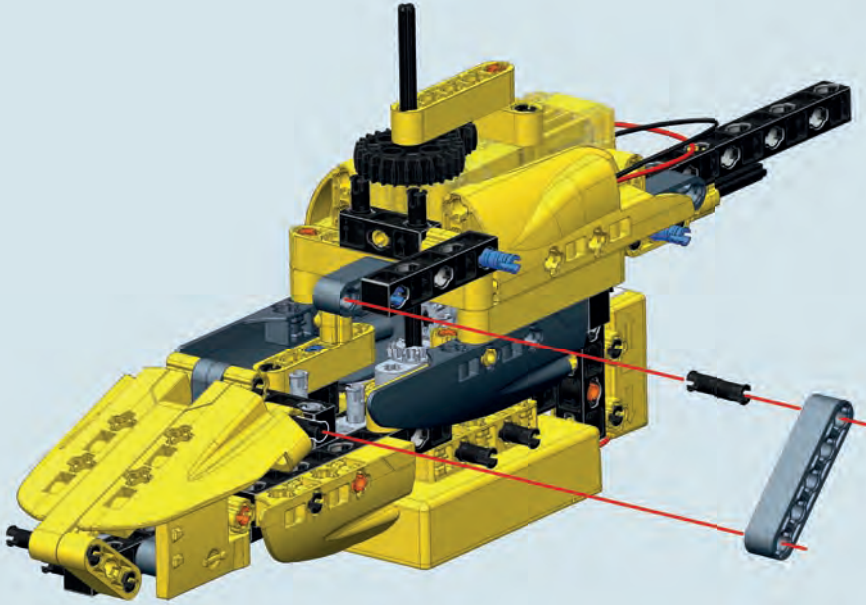

49

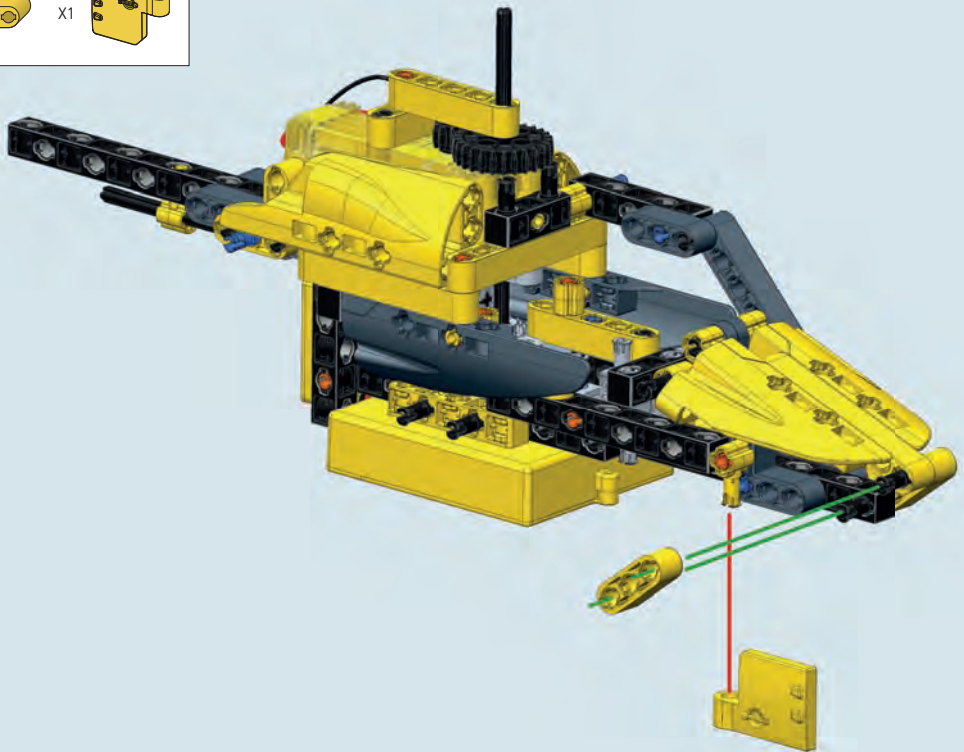
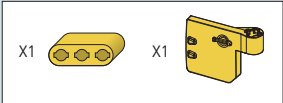

50

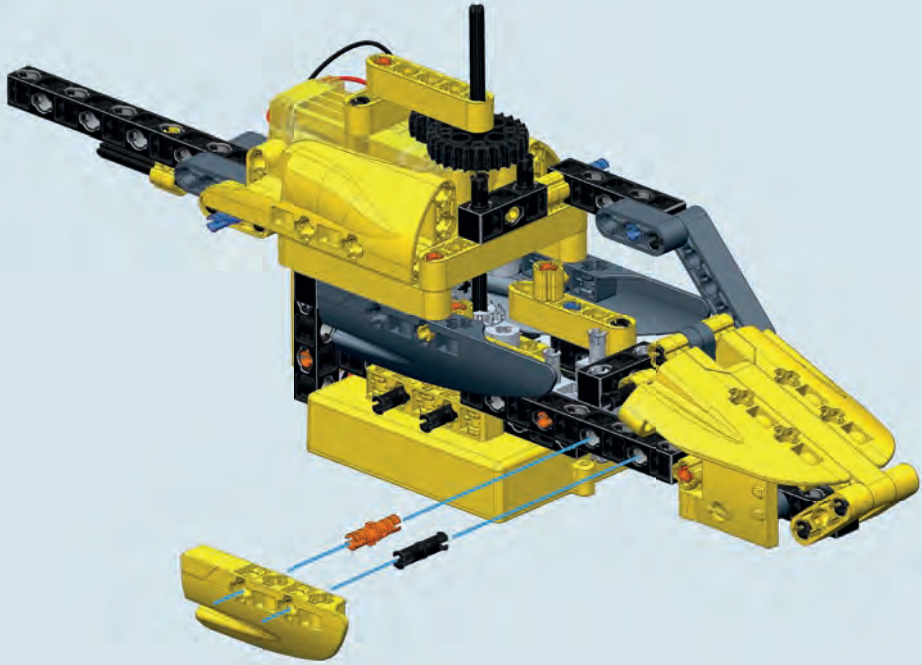

51

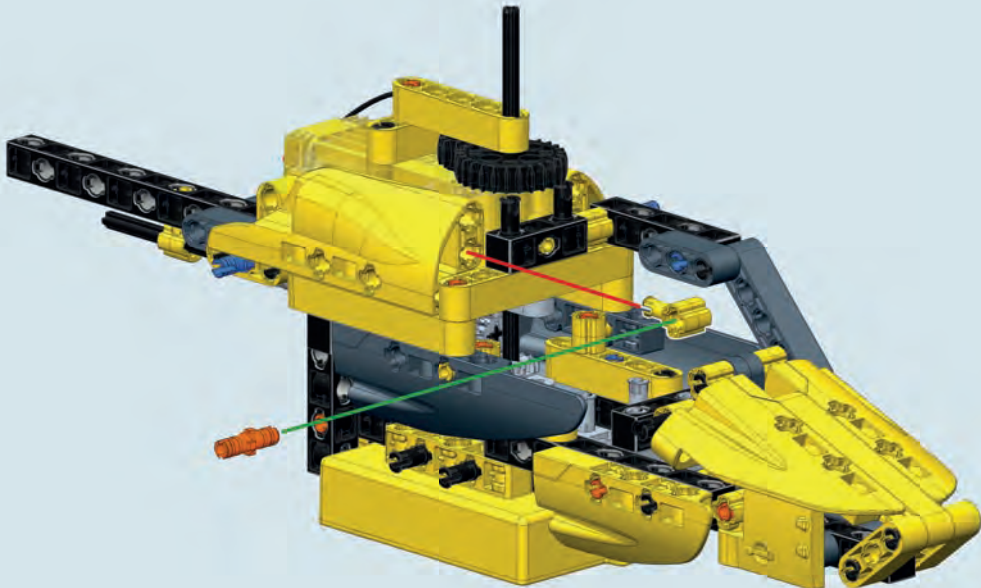
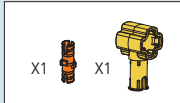

52

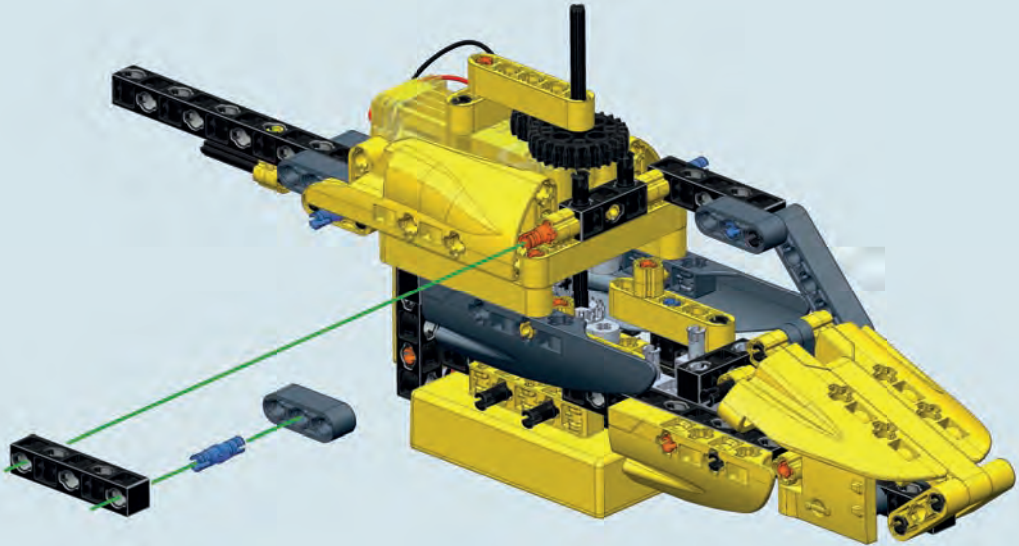

53

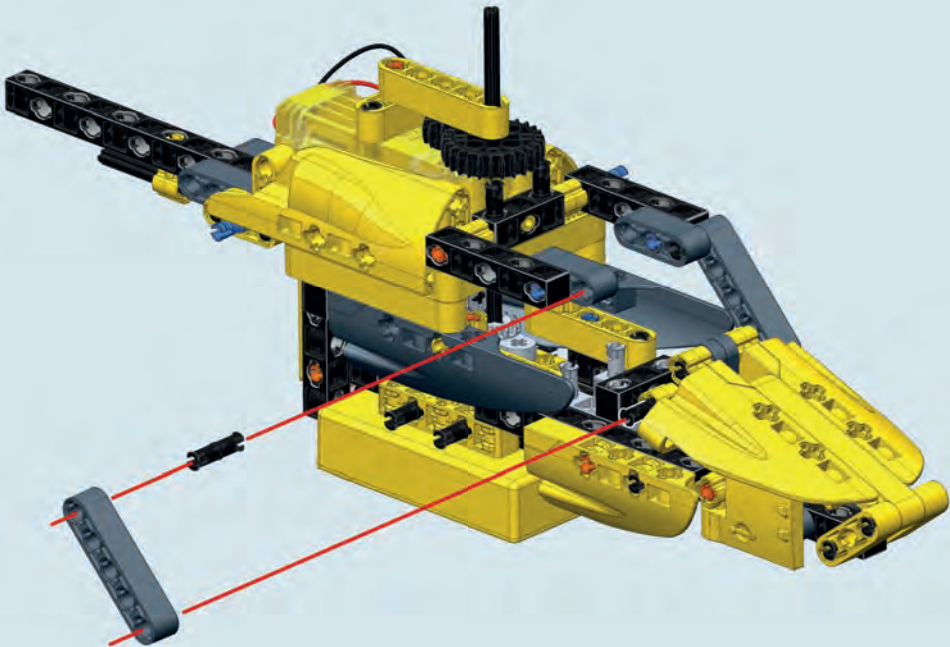

54

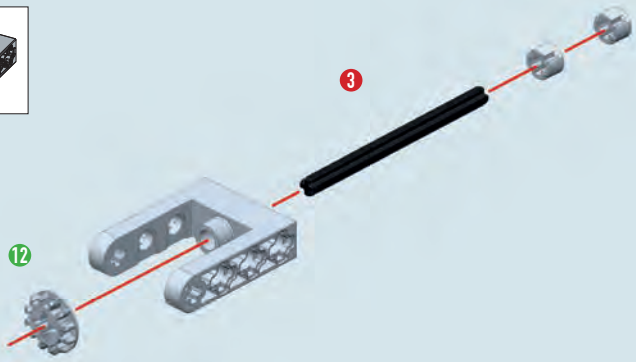
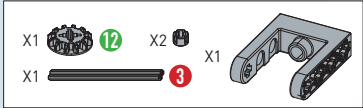



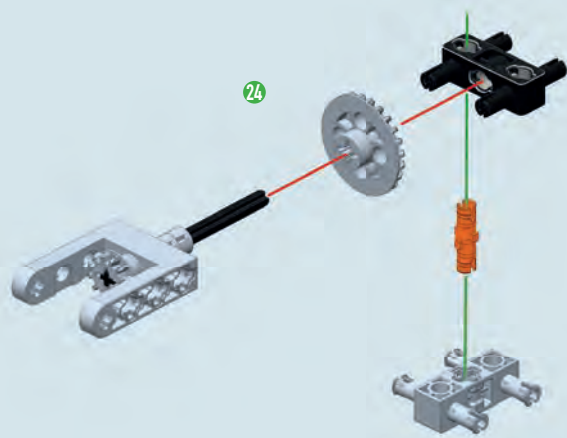
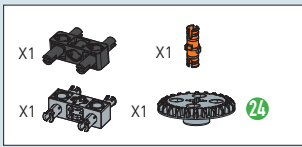

55

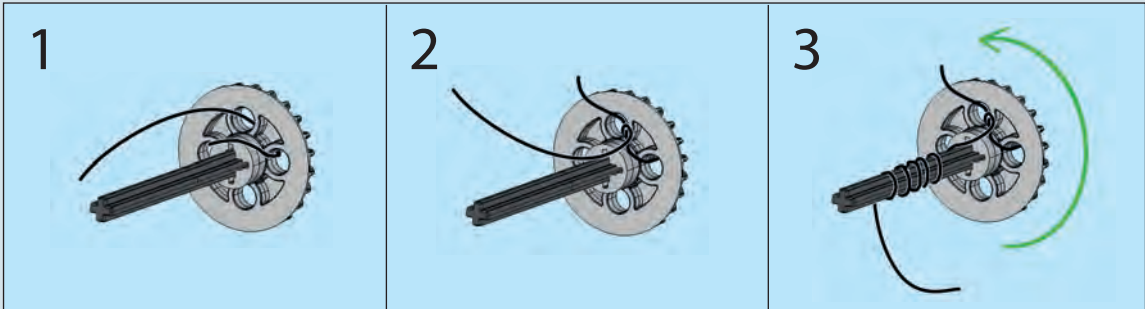
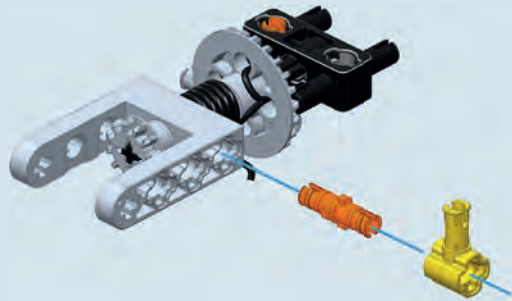
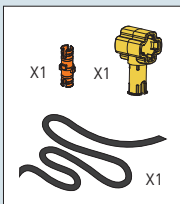

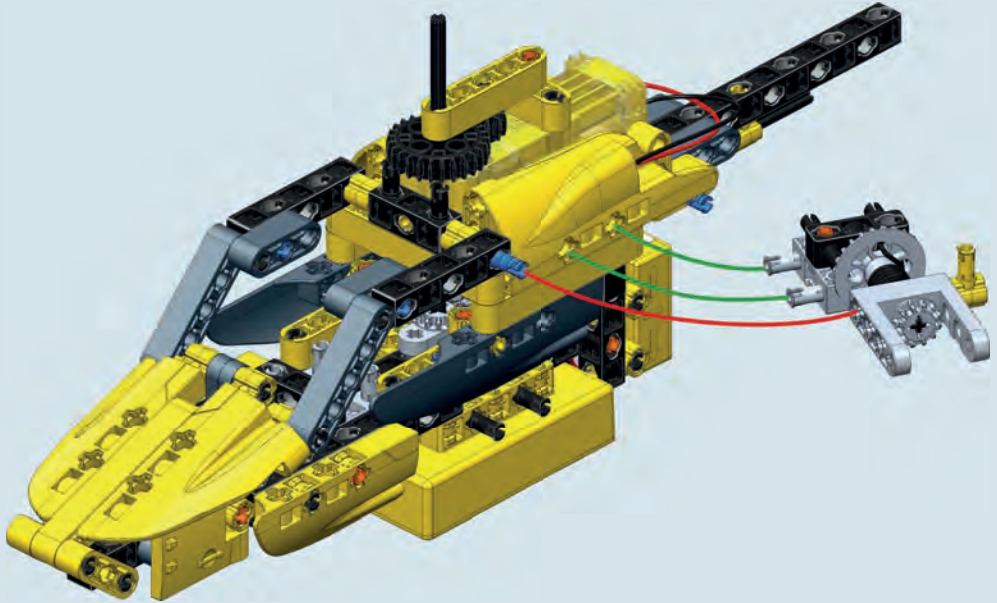
56





- X1   X1  X1 
-  

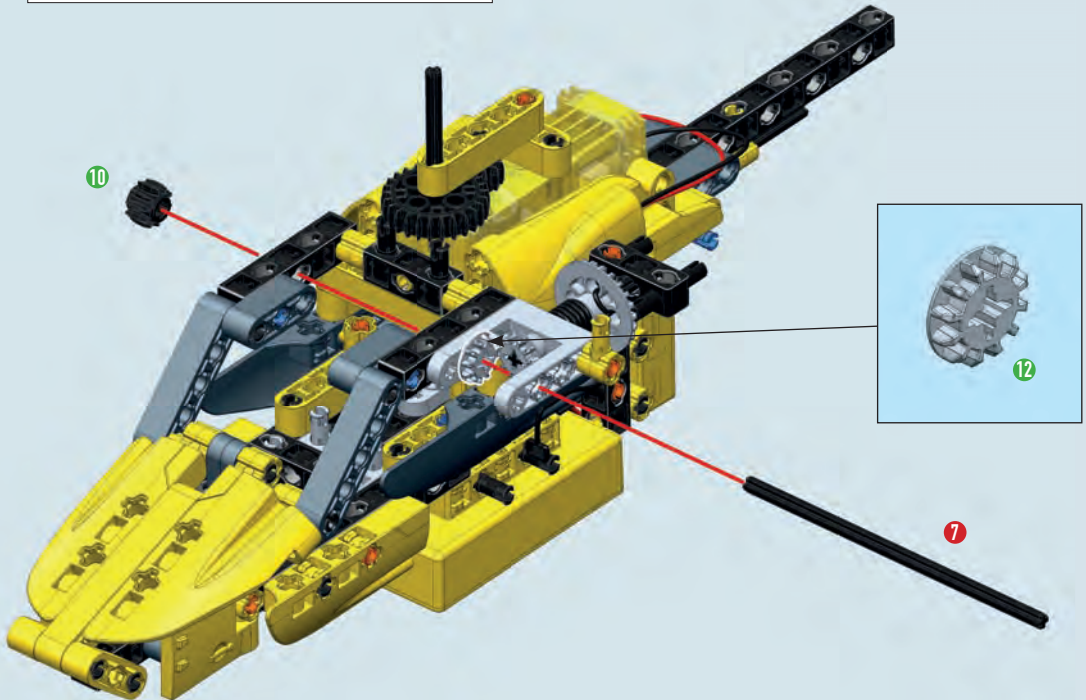

- 1:1  

59

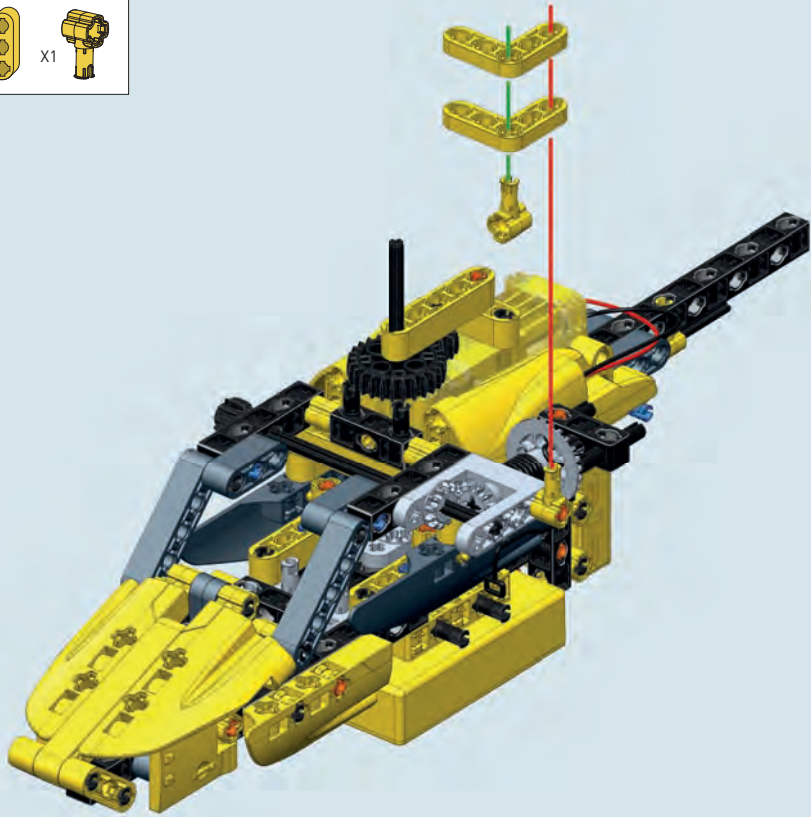
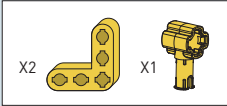

60

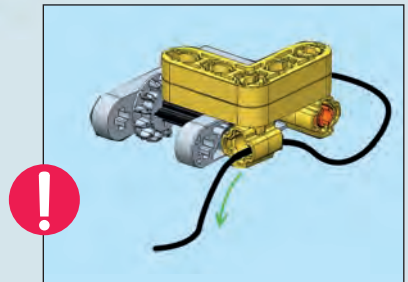
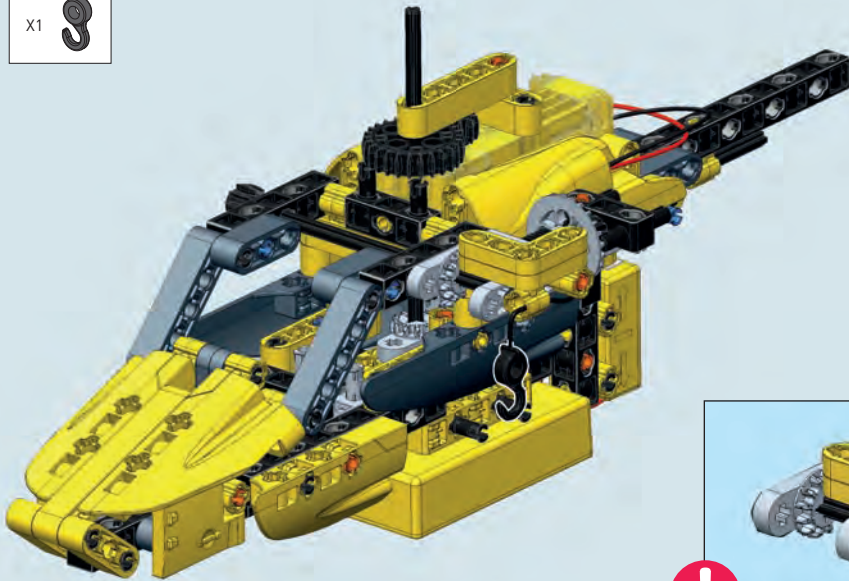

1

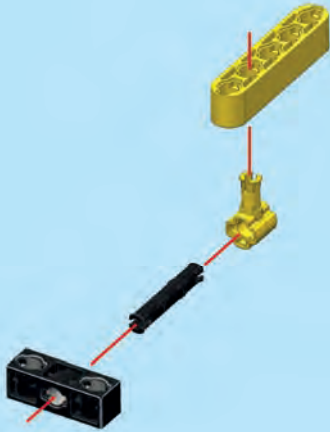

2

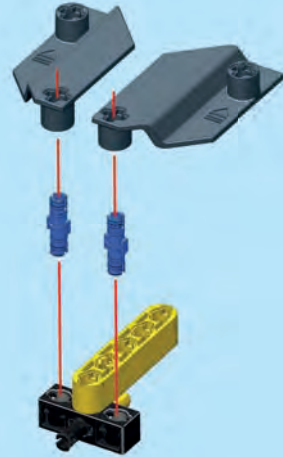

61

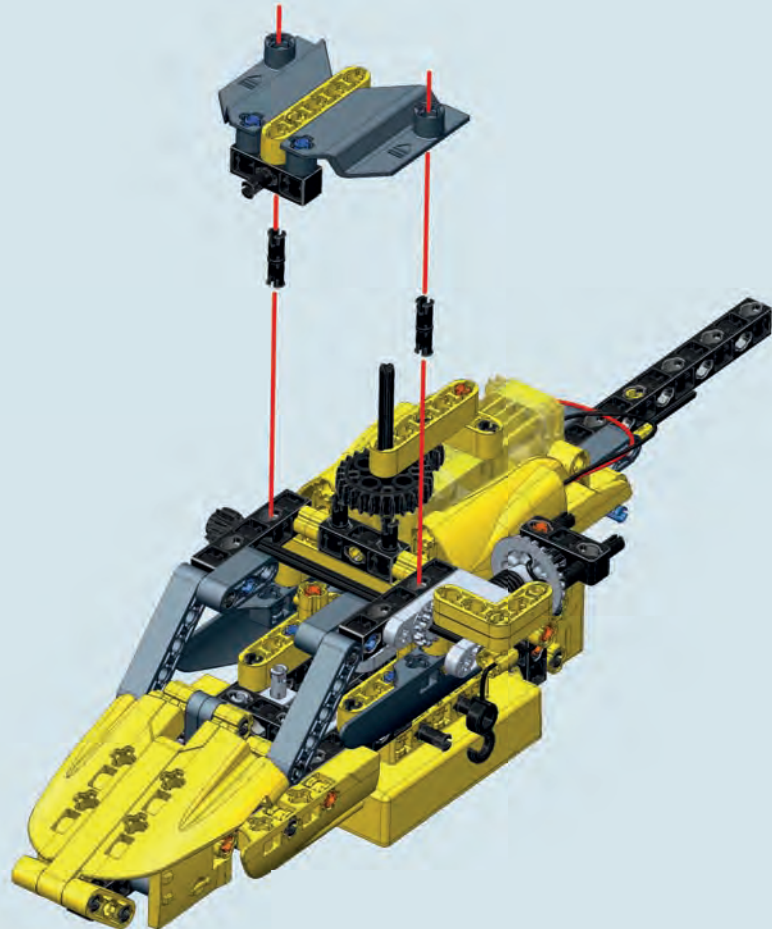
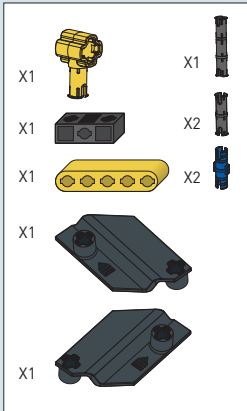

62

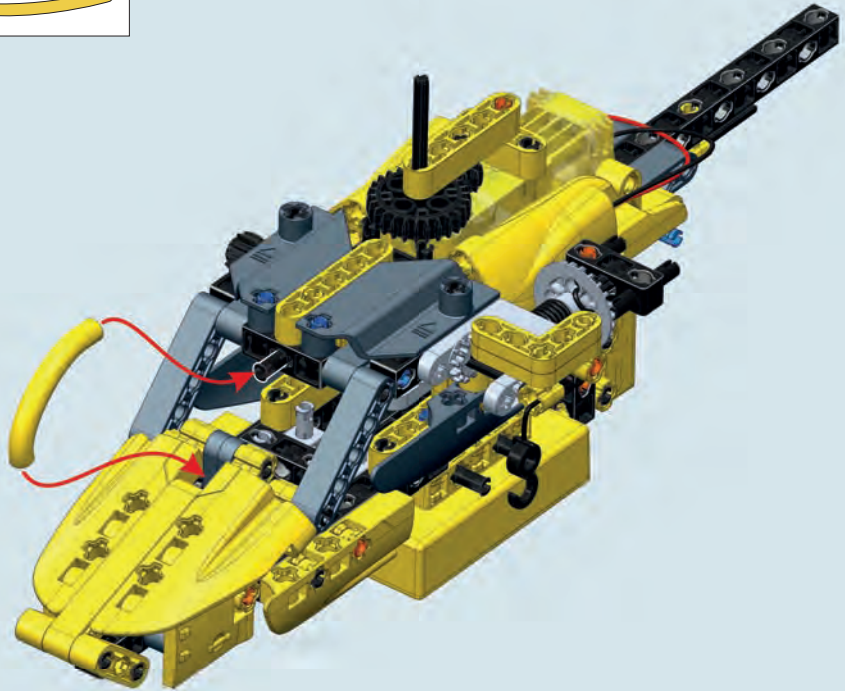

63

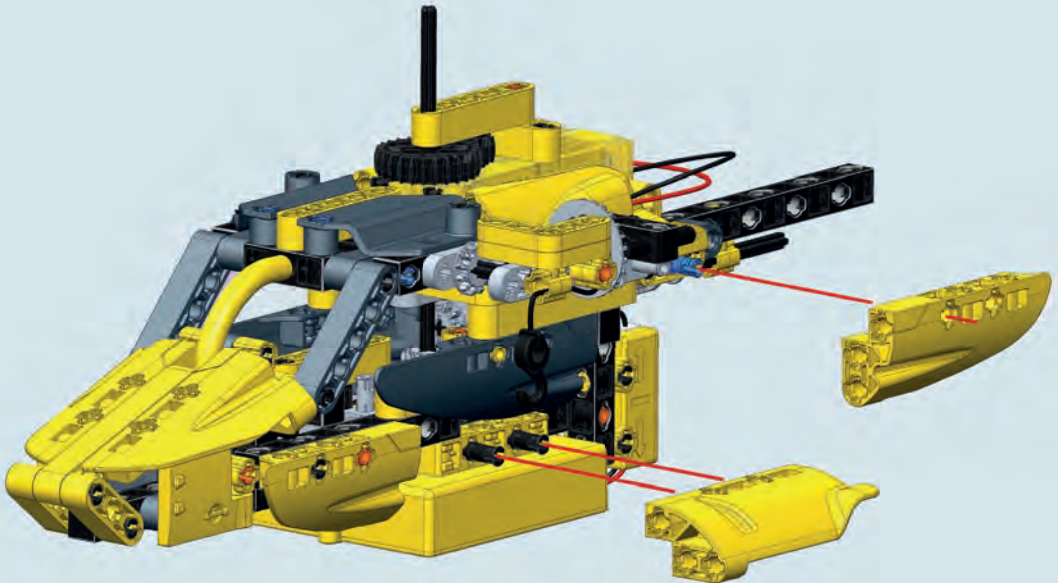

64

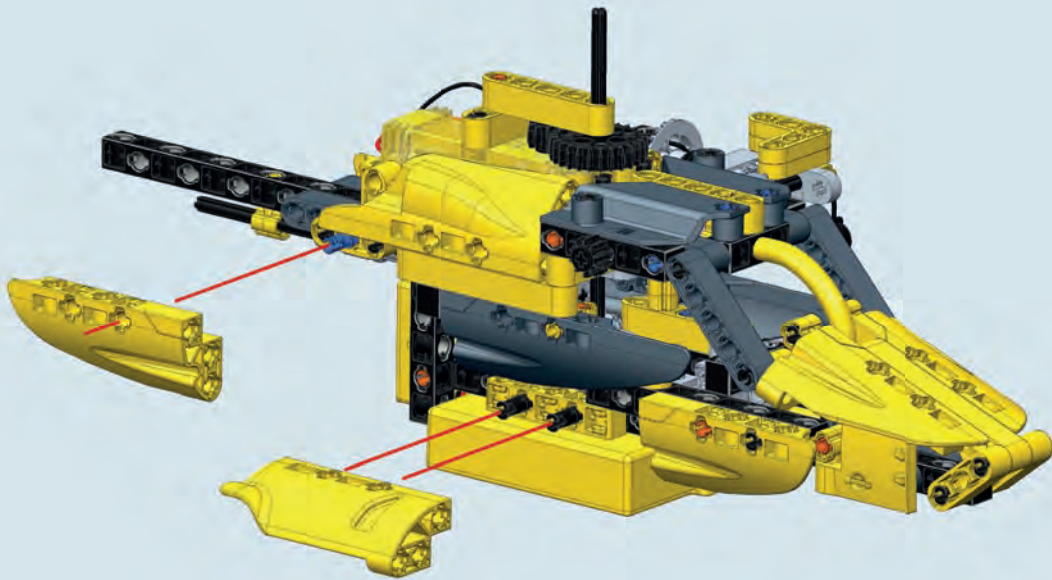
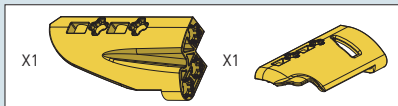

65

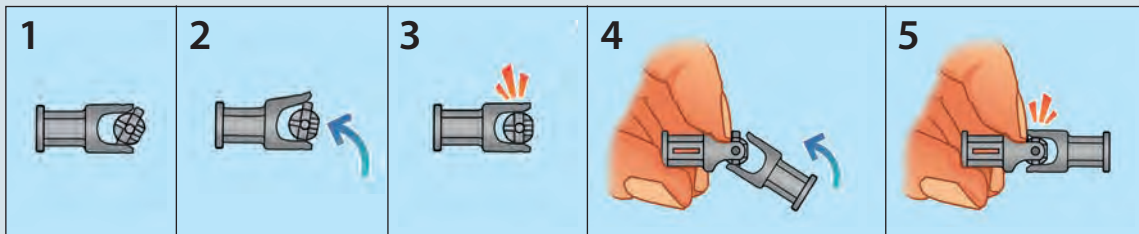
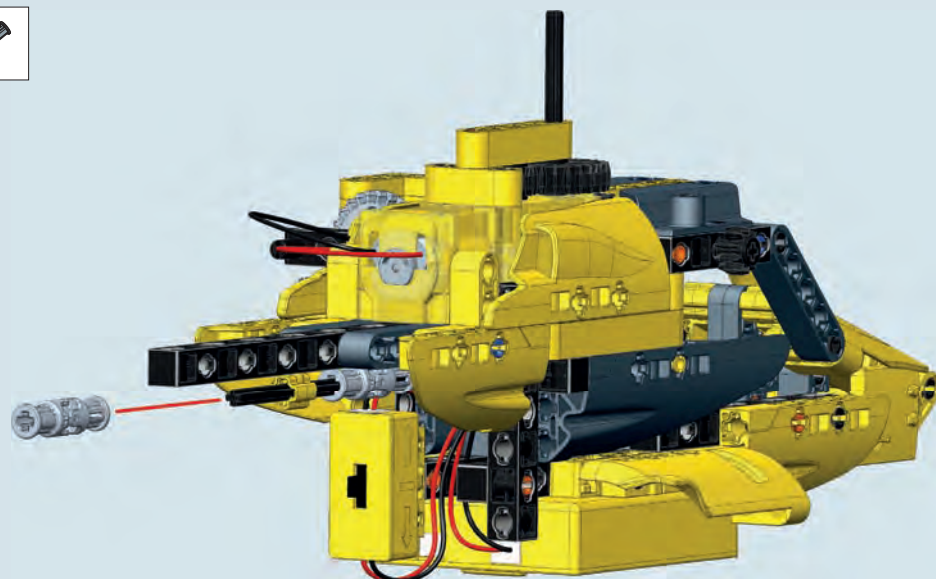

66

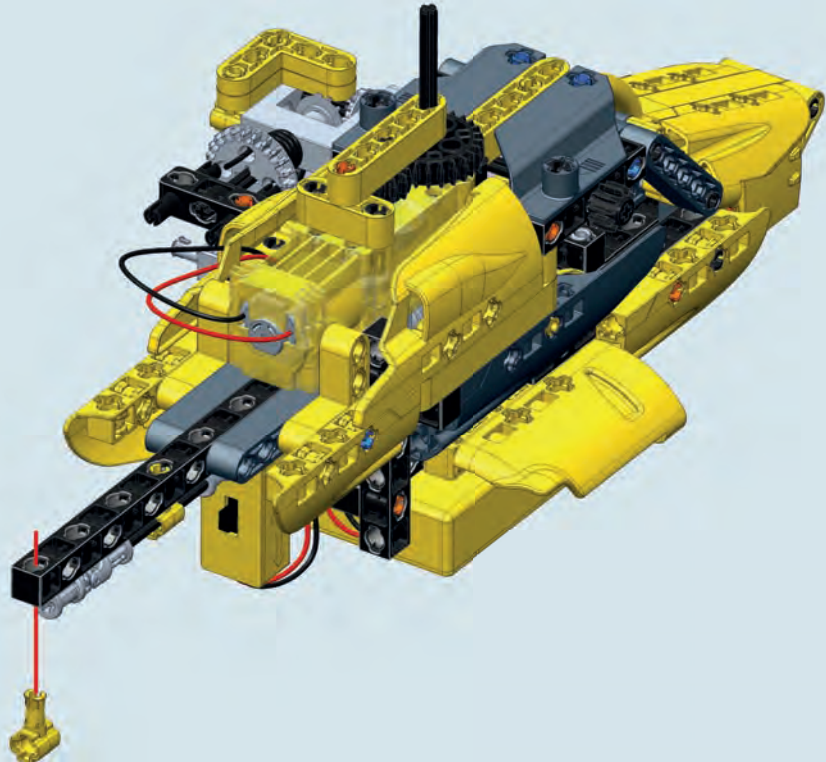

67

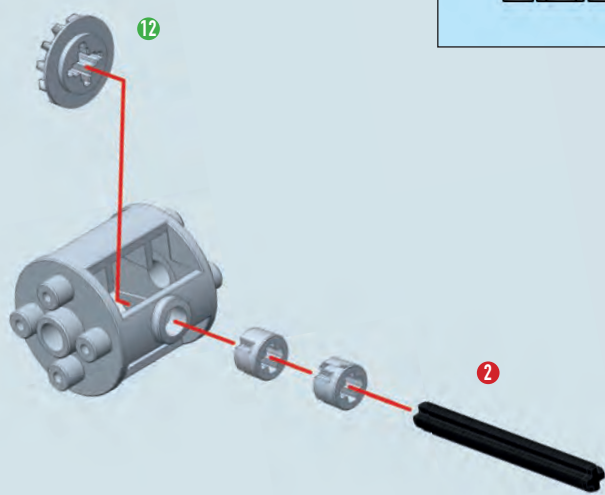
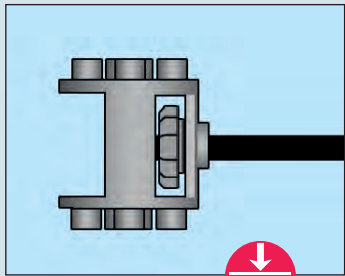
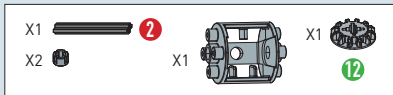

68

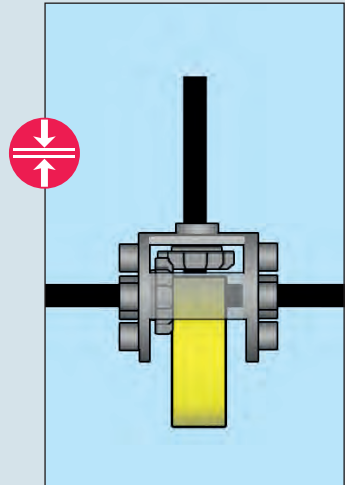
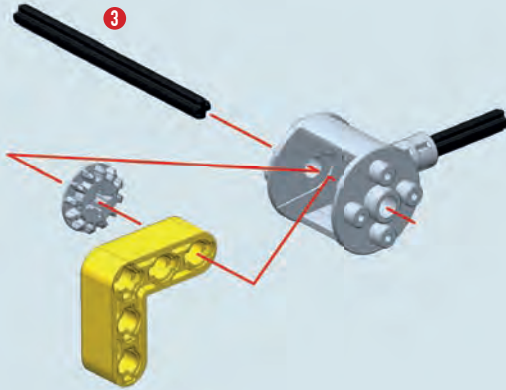
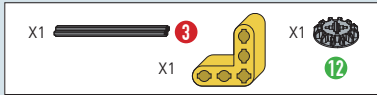

69

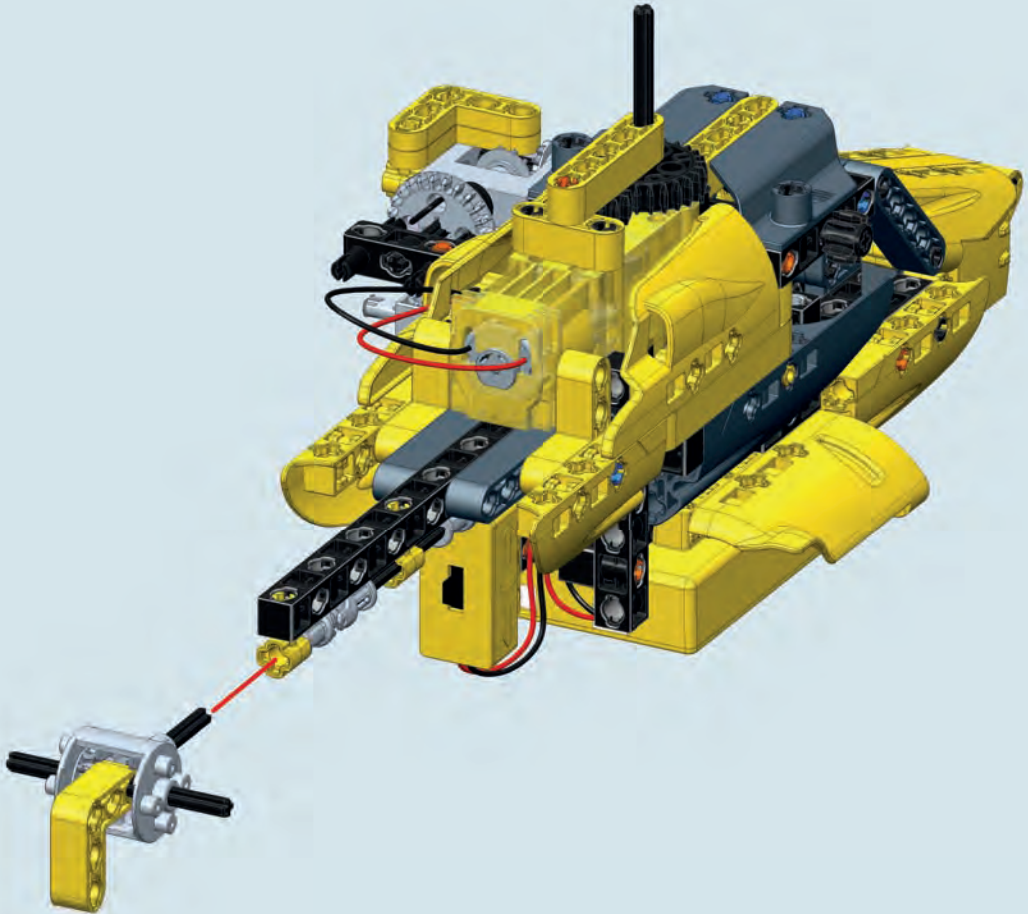

70

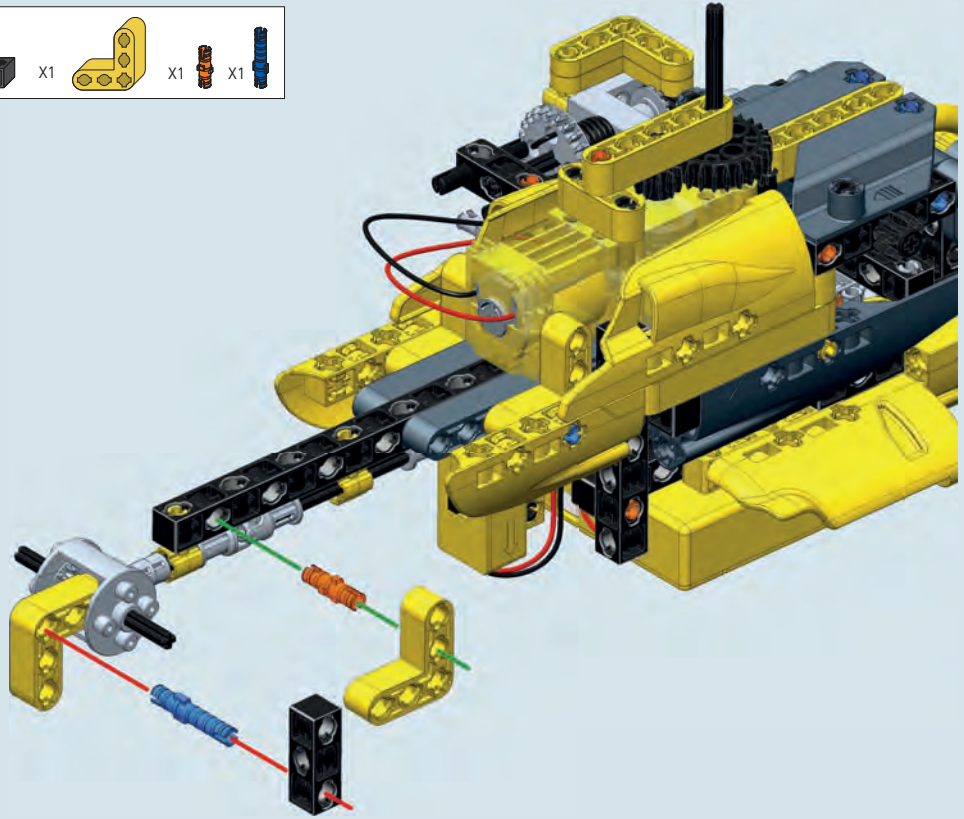
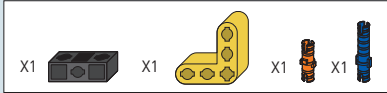

71

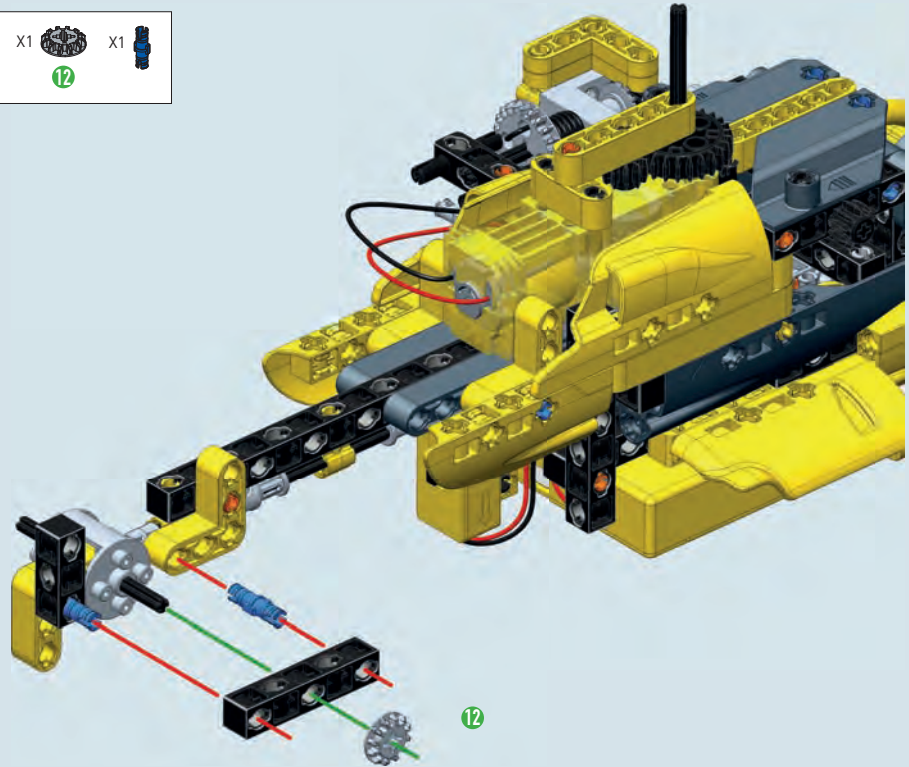

72

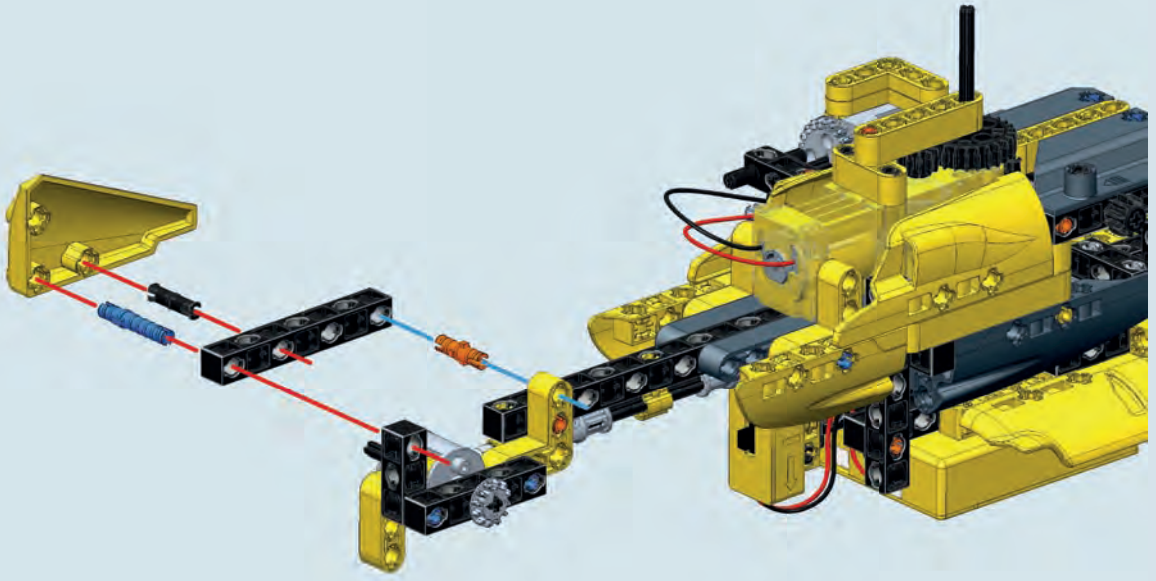
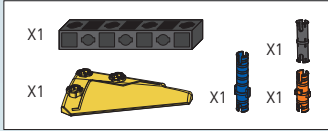

73

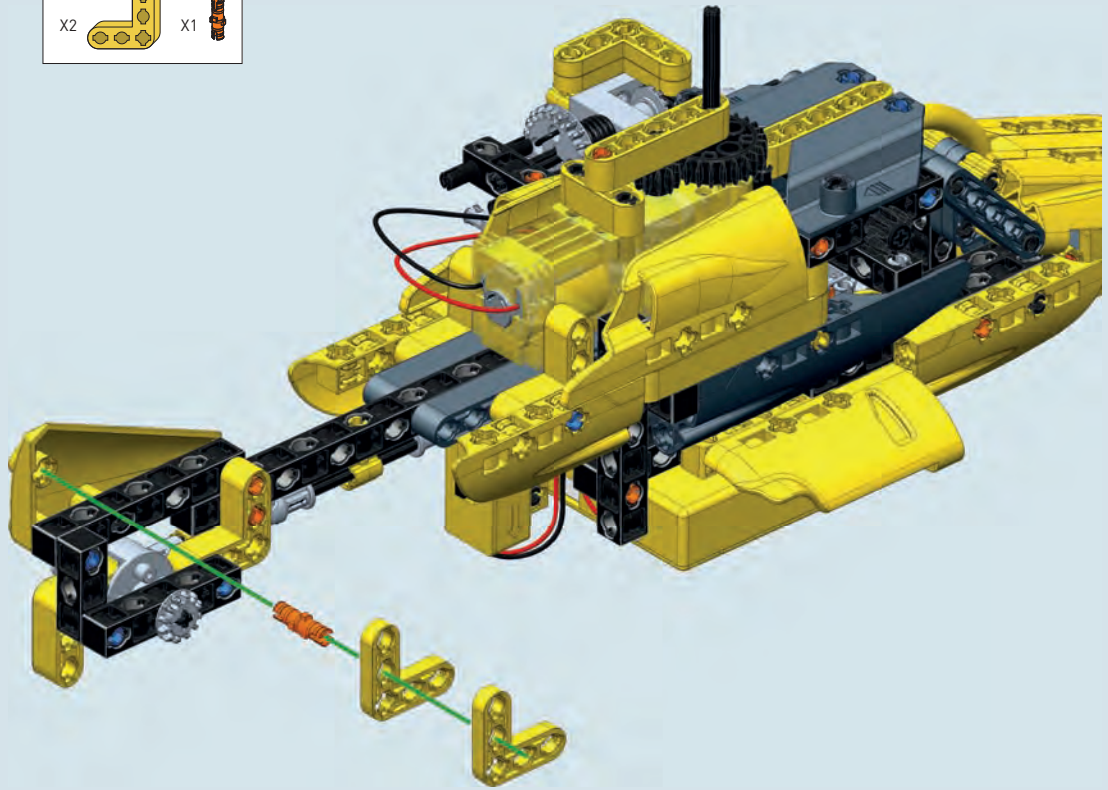

74

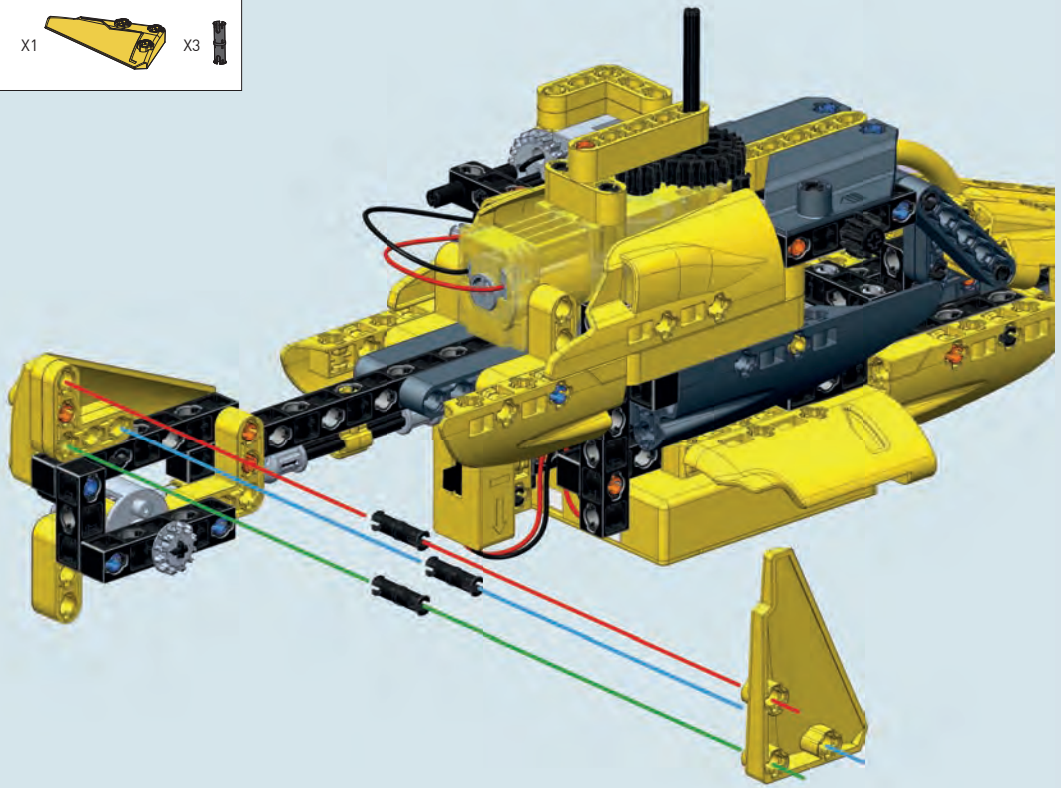
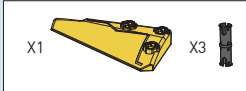

75

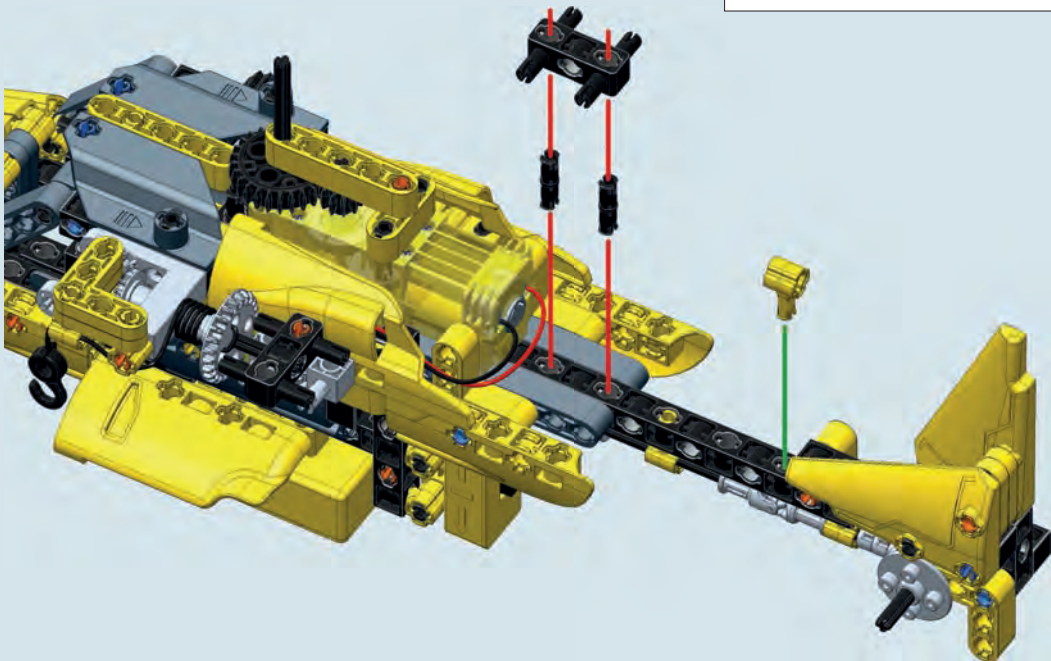



76

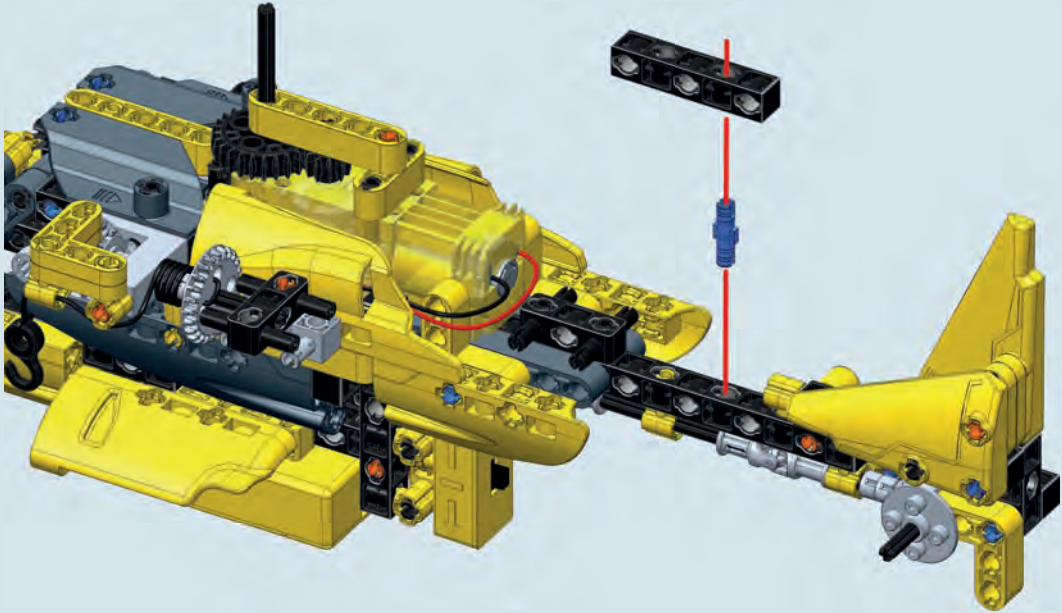

77

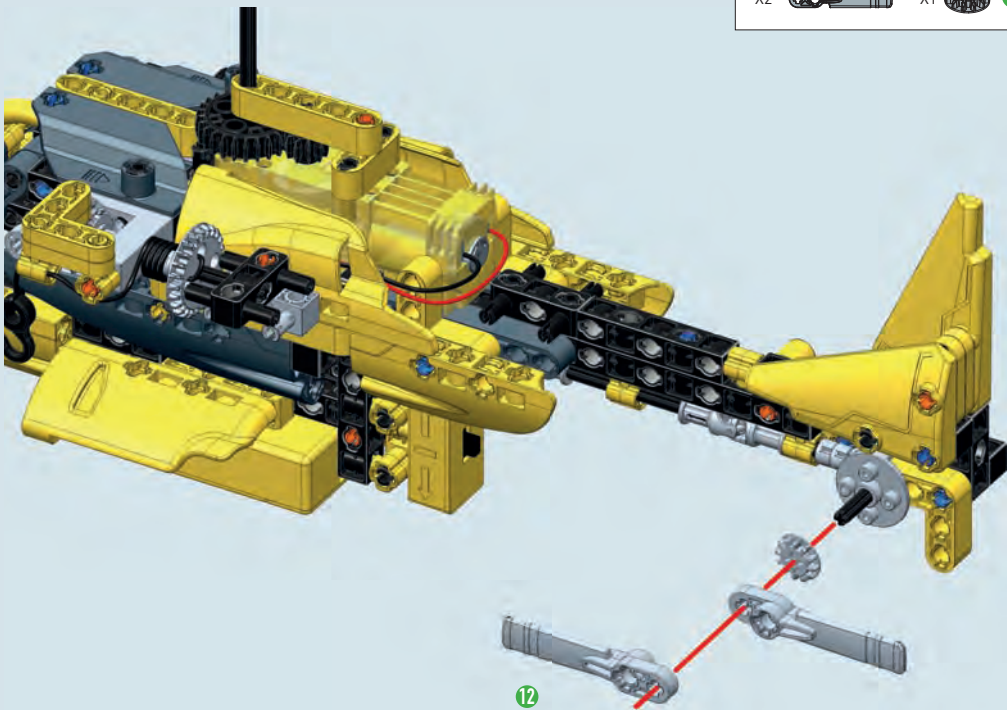

78

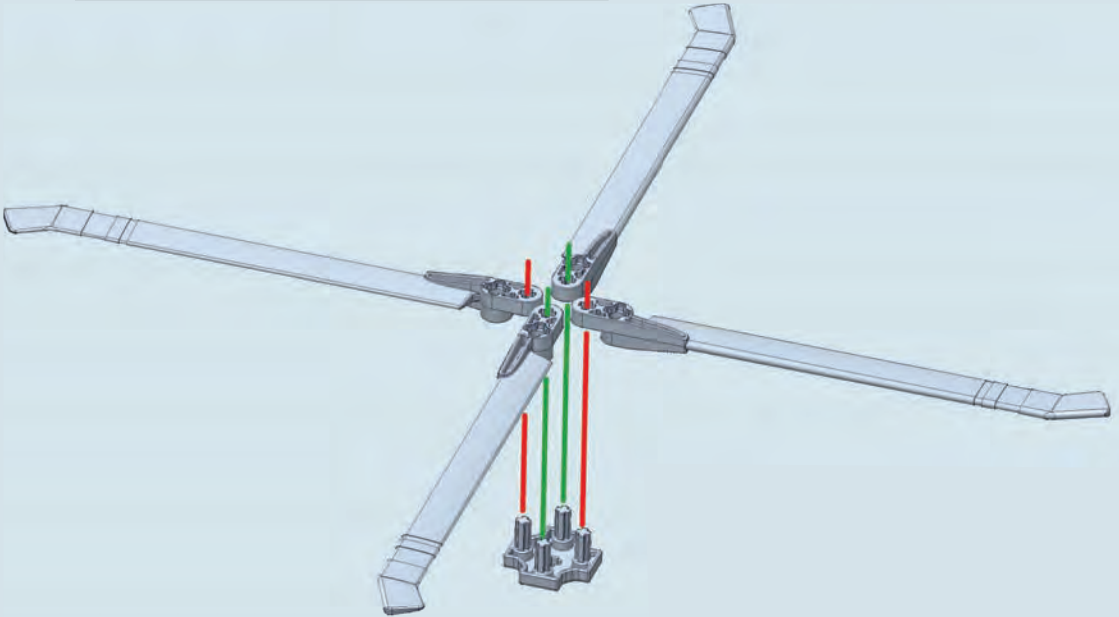
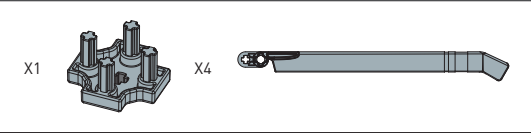

79

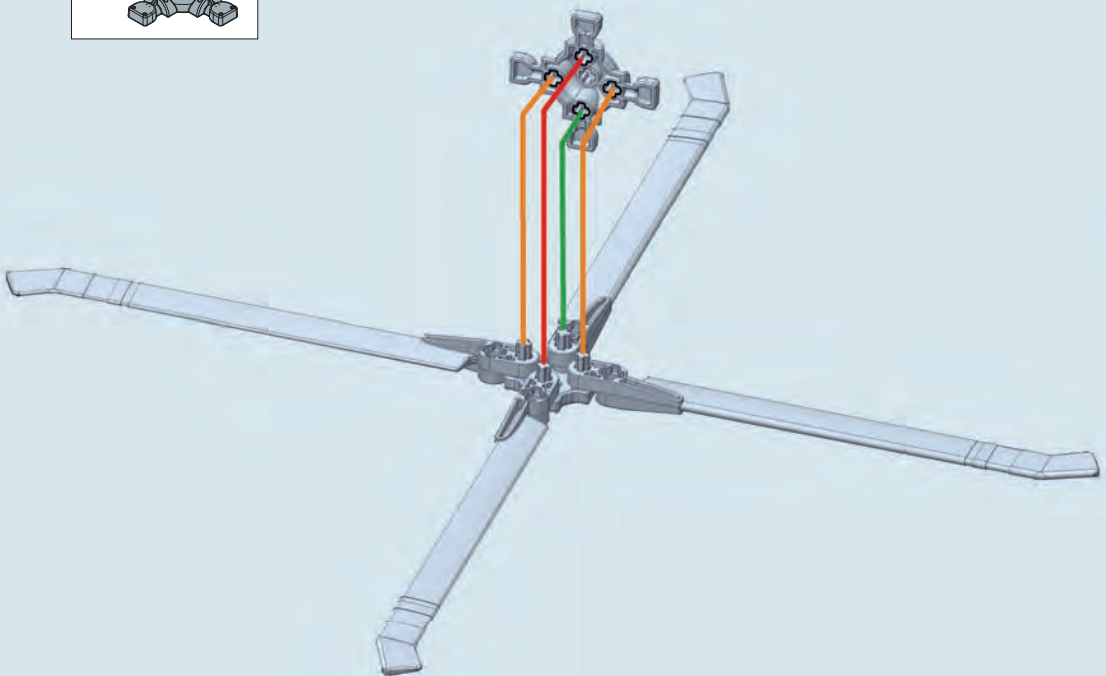
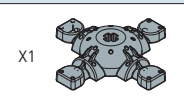



MODELUL ASAMBLAT FINAL

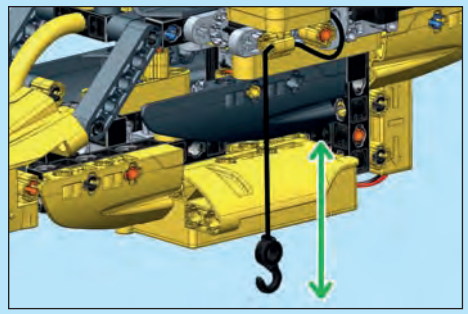
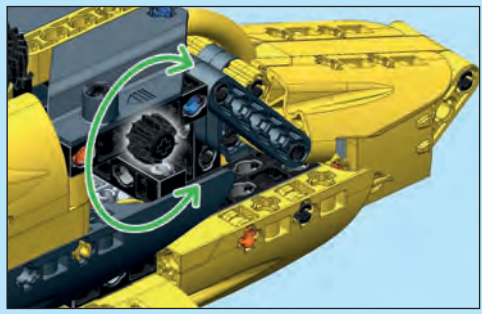
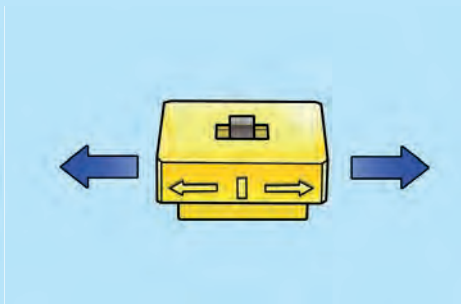
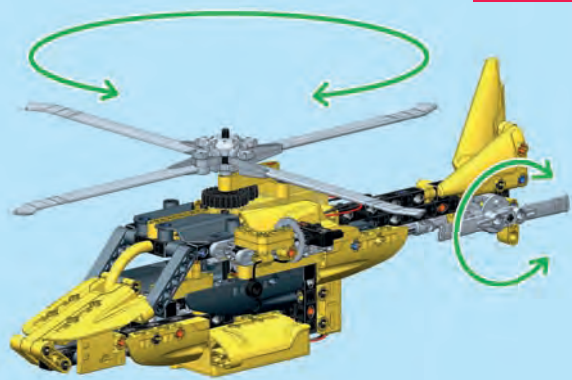



Descarcă gratuit aplicația
Science & Play BUILD.

Animațiile interactive vă
ghidează în procesul de
asamblare a **10 modele
fantastice**, într-un mod
simplu și rapid.

COMPATIBILITATEA APLICAȚIEI

**Aplicația este
compatibilă cu
ANDROID™, APPLE®
și AMAZON®.**

**Nu este compatibilă
cu sistemul de
operare WINDOWS®.**



Descărcați de pe
App Store

Apple și sigla Apple sunt mărci
înregistrate ale Apple Inc.,
înregistrate în S.U.A. și alte țări. App
Store este un serviciu marca Apple
Inc., înregistrat în S.U.A. și în alte țări.



DESCARCĂ DE PE
Google Play

Google Play și sigla Google Play sunt
mărci înregistrate ale Google LLC.

available at
amazon appstore

Amazon și toate siglele aferente sunt
mărci înregistrate ale Amazon.com,
Inc. sau ale afiliaților.

